



Adattatori - Adaptors *Bsi 5200 - Iso 8434-6*



Catalogo - Catalogue
2012

**INDICE
INDEX**

Pag. 4.1 - 4.2 - 4.3 - 4.4 - 4.5 - 4.6 - 4.7 - 4.8

**INFORMAZIONI SUI PRODOTTI E DATI GENERALI
General Information**

Pag. 4.9

**ACCIAI IMPIEGATI
TRATTAMENTO DI FINITURA
Steel Used on all Series
Cleaning Process**

Pag. 4.10

**LUBRIFICAZIONE DEI COMPONENTI
Lubrication of the components**

Pag. 4.11

**TABELLA COMPATIBILITÀ FLUIDI
Fluids Compatibility table**

Pag. 4.12

**TUBI IN ACCIAIO INOSSIDABILE CONSIGLIATI
Recommended Stainless Steel tubes**

Pag. 4.13

**GUARNIZIONI IMPIEGATE
TEMPERATURE AMMESSE E RIDUZIONI DI PRESSIONE
Sealing Materials
Pressure Reductions and Temperature**

Pag. 4.14

**RESPONSABILITÀ
Liability**

Pag. 4.15

**COLLAUDO
Testing**

Pag. 4.16

**COPPIE DI SERRAGGIO
Torque Wrench
Raccordi su Tubazioni
Nut on Tube
Pag. 4.17****COPPIE DI SERRAGGIO
Torque Wrench
Raccordi Girevoli
Swivel Fittings
Pag. 4.18****COPPIE DI SERRAGGIO
Torque Wrench
Filetto Gas Cilindrico e Filetto UNF/UN-2A
BSP and UNF/UN-2A Thread
Pag. 4.19**

COPPIE DI SERRAGGIO
Torque Wrench
Filetto Metrico Cilindrico
Metric Thread
Pag. 4.20

SEDI E FILETTATURE BSP
Thread Coupling – BSP Thread

Pag. 4.21

SEDI E FILETTATURE METRICHE
Thread Coupling – Metric Thread

Pag. 4.22

SEDI E FILETTATURE UNF/UN-2A
Thread Coupling – UNF/UN-2A

Pag. 4.23

SEDI E FILETTATURE NPT
Thread Coupling – NPT

Pag. 4.24



ADATTATORE DIRITTO MASCHIO
Filetto Gas Cilindrico
MALE STRAIGHT ADAPTOR
Thread BSP Parallel

Cod. BSPMA..

Pag. 4.25



ADATTATORE DIRITTO MASCHIO – Sede Piana
Filetto Gas Cilindrico
MALE STRAIGHT ADAPTOR – Flat Seat
Thread BSP Parallel

Cod. BSPFMA..

Pag. 4.26



ADATTATORE MASCHIO DIRITTO CON GUARNIZIONE
Filetto Gas Cilindrico
MALE STRAIGHT ADAPTOR WITH CAPTIVE SEAL
Thread BSP Parallel

Cod. BSPMA..V

Pag. 4.27



ADATTATORE MASCHIO DIRITTO CON DOPPIA GUARNIZIONE
Filetto Gas Cilindrico
MALE STRAIGHT ADAPTOR WITH DOUBLE CAPTIVE SEAL
Thread BSP Parallel

Cod. BSPMA..DV

Pag. 4.28



ADATTATORE MASCHIO DI RIDUZIONE
Filetto Gas Cilindrico
MALE STRAIGHT REDUCING ADAPTOR
Thread BSP Parallel

Cod. BSPMRA..

Pag. 4.29



ADATTATORE DIRITTO MASCHIO
Filetto Metrico Cilindrico
MALE STRAIGHT ADAPTOR
Thread Metric Parallel

Cod. MMA.. – MMRA..

Pag. 4.30



ADATTATORE DIRITTO MASCHIO
Filetto Gas Conico
MALE STRAIGHT ADAPTOR
Thread BSP Taper

Cod. BSPTMA.. – BSPTMRA..

Pag. 4.31



ADATTATORE DIRITTO MASCHIO
Filetto NPT
MALE STRAIGHT ADAPTOR
Thread NPT

Cod. NPTMA.. - NPTMRA..

Pag. 4.32



ADATTATORE DIRITTO MASCHIO
Filetto Gas Cilindrico/Metrico Cilindrico
MALE STRAIGHT ADAPTOR
Thread Bsp Parallel/Metric Parallel

Cod. MBSPMA..

Pag. 4.33



ADATTATORE MASCHIO DIRITTO
Filetto Gas Cilindrico/Conico
MALE STRAIGHT ADAPTOR
Thread BSP Parallel/BSP Taper

Cod. BSPBSPTMA.. - BSPBSPTMRA..

Pag. 4.34



ADATTATORE MASCHIO DIRITTO
Filetto Gas Cilindrico/NPT
MALE STRAIGHT ADAPTOR
Thread BSP Parallel/NPT

Cod. BSPNPTMA.. - BSPNPTMRA..

Pag. 4.35



ADATTATORE DIRITTO MASCHIO
Filetto Gas Conico/NPT
MALE STRAIGHT ADAPTOR
Thread BSP Taper/NPT

Cod. BSPTNPTMA..

Pag. 4.36



PASSAPARETE MASCHIO CON DADO
Filetto Gas Cilindrico
BULKHEAD UNION (WITH NUT)
Thread BSP Parallel

Cod. BBSPMA..

Pag. 4.37



ADATTATORE DIRITTO FEMMINA
Filetto Gas Cilindrico
FEMALE UNION
Thread Bsp Parallel

Cod. BSPFFA.. - BSPFFRA..

Pag. 4.38



ADATTATORE DIRITTO FEMMINA
Filetto Metrico Cilindrico
FEMALE UNION
Thread Metric Parallel

Cod. MFFA..

Pag. 4.39



ADATTATORE DIRITTO FEMMINA
Filetto Gas Conico
FEMALE UNION
Thread BSP Taper

Cod. BSPTFFA.. - BSPTFFRA..

Pag. 4.40



ADATTATORE DIRITTO FEMMINA
Filetto NPT
FEMALE UNION
Thread NPT

Cod. NPTFFA.. - NPTFFRA..

Pag. 4.41



ADATTATORE FEMMINA/FEMMINA
GIREVOLE
Filetto Gas Cilindrico
FEMALE SWIVEL ADAPTOR
Thread BSP Parallel

Cod. BSPSFA..

Pag. 4.42



PROLUNGA DIRITTA
MASCHIO/FEMMINA
Filetto Gas Cilindrico
MALE/FEMALE CONNECTOR
Thread BSP Parallel

Cod. BSPMFFA..

Pag. 4.43



**ADATTATORE DIRITTA
MASCHIO/FEMMINA - SERIE LUNGA**
Filetto Gas Cilindrico
**MALE/FEMALE
CONNECTOR (LONG TYPE)**
Thread BSP Parallel

Cod. **BSPMFFA..L**

Pag. 4.44



**TAPPO DI RIDUZIONE
MASCHIO/FEMMINA**
Filetto Gas Cilindrico
MALE/FEMALE REDUCING PLUG
Thread BSP Parallel

Cod. **BSPMFRP..**

Pag. 4.45



**PROLUNGA DIRITTA
MASCHIO/FEMMINA**
Filetto Metrico Cilindrico
MALE/FEMALE CONNECTOR
Thread Metric Parallel

Cod. **MMFFA..**

Pag. 4.46



**PROLUNGA DIRITTA
MASCHIO/FEMMINA - SERIE LUNGA**
Filetto Metrico Cilindrico
**MALE/FEMALE
CONNECTOR (LONG TYPE)**
Thread Metric Parallel

Cod. **MMFFA..L**

Pag. 4.47



**PROLUNGA DIRITTA
MASCHIO/FEMMINA**
Filetto NPT
MALE/FEMALE CONNECTOR
Thread NPT

Cod. **NPTMFFA..**

Pag. 4.48



**ADATTATORE MASCHIO/FEMMINA
GIREVOLE**
Filetto Gas Cilindrico
MALE/SWIVEL FEMALE CONNECTOR
Thread BSP Parallel

Cod. **BSPMSFA..**

Pag. 4.49



**ADATTATORE MASCHIO/FEMMINA
GIREVOLE CON GUARNIZIONE**
Filetto Gas Cilindrico
**MALE/SWIVEL FEMALE CONNECTOR
WITH CAPTIVE SEAL**
Thread BSP Parallel

Cod. **BSPMSFA..V**

Pag. 4.50



**ADATTATORE MASCHIO/FEMMINA
GIREVOLE**
Filetto Maschio NPT/Femmina NPSM
**MALE/SWIVEL FEMALE CONNECTOR
WITH O'RING - S SERIES**
Male Thread NPT/Female Thread NPSM

Cod. **NPTMSFA..**

Pag. 4.51



**ADATTATORE MASCHIO/FEMMINA
GIREVOLE**
Filetto Maschio Gas Conico/
Femmina Gas Cilindrico
MALE/SWIVEL FEMALE CONNECTOR
Male Thread BSP Taper/
Female Thread BSP Parallel

Cod. **BSPTBSMSFA..**

Pag. 4.52



**ADATTATORE MASCHIO/FEMMINA
GIREVOLE**
Filetto Maschio NPT/
Femmina Gas Cilindrico
MALE/SWIVEL FEMALE CONNECTOR
Male Thread NPT/
Female Thread BSP Parallel

Cod. **NPTBSPMSFA..**

Pag. 4.53



**ADATTATORE A 90°
MASCHIO INTERMEDIO**
Filetto Gas Cilindrico
MALE EQUAL ELBOW
Thread BSP Parallel

Cod. **LBSPMA..**

Pag. 4.54



**ADATTATORE A 90°
MASCHIO INTERMEDIO**
Filetto Metrico Cilindrico
MALE EQUAL ELBOW
Thread Metric Parallel

Cod. **LMMA..**

Pag. 4.55



ADATT. A 90° E A T MASCHIO INTER.
Filetto Gas Conico
MALE EQUAL ELBOW AND TEE
Thread BSP Taper

Cod. **LBSPDMA..TBSPTMA..**

Pag. 4.56



ADATT. A 90° E A T MASCHIO INTER.
Filetto NPT
MALE EQUAL ELBOW AND TEE
Thread NPT

Cod. **LNPTMA..TNPTMA..**

Pag. 4.57



ADATTATORE A 90°
MASCHIO DI ESTREMITÀ
Filetto Gas Cilindrico/Conico
MALE STUD ELBOW
Thread BSP Parallel/BSP Taper

Cod. **LBSPBSPTMA..**

Pag. 4.58



ADATTATORE A 90°
MASCHIO DI ESTREMITÀ
Filetto Gas Cilindrico/NPT
MALE STUD ELBOW
Thread BSP Parallel/NPT

Cod. **LBSPNPTMA..**

Pag. 4.59



ADATTATORE A 90° FEMMINA
INTERMEDIO
Filetto Gas Cilindrico
FEMALE EQUAL ELBOW
Thread BSP Parallel

Cod. **LBSPFFA..**

Pag. 4.60



ADATTATORE A 90° FEMMINA
INTERMEDIO
Filetto NPT
FEMALE EQUAL ELBOW
Thread NPT

Cod. **LNPTFFA..**

Pag. 4.61

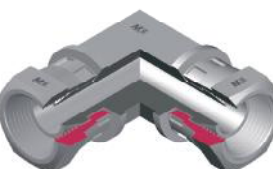

ADATTATORE A 90° FEMMINA
GIREVOLE
Filetto Gas Cilindrico
**SWIVEL FEMALE
EQUAL ELBOW**
Thread BSP Parallel

Cod. **LBSPSFA..**

Pag. 4.62

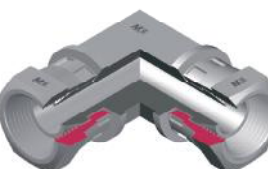

ADATTATORE A 90° FEMMINA
GIREVOLE
Filetto Metrico Cilindrico
**SWIVEL FEMALE
EQUAL ELBOW**
Thread Metric Parallel

Cod. **LMSFA..**

Pag. 4.63



ADATTATORE A 90°
FEMMINA/FEMMINA GIREVOLE
Filetto Gas Cilindrico
90° SWIVEL ELBOW FEMALE/FEMALE
Thread BSP Parallel

Cod. **90BSPSFA..**

Pag. 4.64



ADATTATORE A 90°
MASCHIO/FEMMINA
Filetto Gas Conico/Cilindrico
MALE/FEMALE STUD ELBOW
Thread BSP Taper/BSP Parallel

Cod. **LBSPBSPMFA..**

Pag. 4.65



ADATTATORE A 90°
MASCHIO/FEMMINA
Filetto NPT/Gas Cilindrico
MALE/FEMALE STUD ELBOW
Thread NPT/BSP Parallel

Cod. **LNPTBSPMFA..**

Pag. 4.66



ADATTATORE A 90° **MASCHIO/
FEMMINA GIREVOLE**
Filetto Gas Cilindrico
**MALE/SWIVEL FEMALE
STUD ELBOW**
Thread BSP Parallel

Cod. **LBSPMSFA..**

Pag. 4.67



**ADATTATORE A 90° MASCHIO
/FEMMINA GIREVOLE**
Filetto Metrico Cilindrico
**MALE/SWIVEL FEMALE
STUD ELBOW**
Thread Metric Parallel

Cod. LMMSFA..

Pag. 4.68



**ADATTATORE A 90° MASCHIO
/FEMMINA GIREVOLE**
Filetto Maschio Gas Conico
/Femmina Gas Cilindrico
**MALE/SWIVEL FEMALE
STUD ELBOW**
Male Thread BSP Taper
/Female Thread BSP Parallel
Cod. LBSPTBSPMSFA..

Pag. 4.69



**ADATTATORE A 90° MASCHIO
/FEMMINA GIREVOLE**
Filetto Maschio NPT
/Femmina Gas Cilindrico
**MALE/SWIVEL FEMALE
STUD ELBOW**
Male Thread NPT
/Female Thread BSP Parallel
Cod. LNPTBSPMSFA..

Pag. 4.70



**ADATTATORE A 90° MASCHIO
/FEMMINA GIREVOLE**
Filetto Gas Cilindrico
90° SWIVEL ELBOW MALE/FEMALE
Thread BSP Parallel

Cod. 90BSPMSFA..

Pag. 4.71



**ADATTATORE A "T"
INTERMEDIO MASCHIO**
Filetto Gas Cilindrico
MALE EQUAL TEE
Thread BSP Parallel

Cod. TBSPMA..

Pag. 4.72



**ADATTATORE A "T"
INTERMEDIO MASCHIO**
Filetto Metrico Cilindrico
MALE EQUAL TEE
Thread Metric Parallel

Cod. TMMA..

Pag. 4.73



**ADATTATORE A "T" MASCHIO DI
ESTREMITÀ LATERALE**
Filetto Gas Cilindrico/Conico
MALE STUD BARREL TEE
Thread BSP Parallel/BSP Taper

Cod. TLBSPBSPTMA..

Pag. 4.74



**ADATTATORE A "T" MASCHIO DI
ESTREMITÀ LATERALE**
Filetto Gas Cilindrico/NPT
MALE STUD BARREL TEE
Thread BSP Parallel/NPT

Cod. TLBSPNPTMA..

Pag. 4.75



**ADATTATORE A "T" MASCHIO DI
ESTREMITÀ CENTRALE**
Filetto Gas Cilindrico/Conico
MALE STUD BRANCH TEE
Thread BSP Parallel/BSP Taper

Cod. TCBSPTSPTMA..

Pag. 4.76



**ADATTATORE A "T" MASCHIO DI
ESTREMITÀ CENTRALE**
Filetto Gas Cilindrico/NPT
MALE STUD BRANCH TEE
Thread BSP Parallel/NPT

Cod. TCBSPNPTMA..

Pag. 4.77



ADATTATORE A "T" INTER. FEMMINA
Filetto Gas Cilindrico
FEMALE EQUAL TEE
Thread BSP Parallel

Cod. TBSPFFA..

Pag. 4.78



ADATTATORE A "T" INTER. FEMMINA
Filetto NPT
FEMALE EQUAL TEE
Thread NPT

Cod. TNPTFFA..

Pag. 4.79



**ADATTATORE A "T" INTERMEDIO
FEMMINA GIREVOLE**
Filetto Gas Cilindrico
SWIVEL FEMALE EQUAL TEE
Thread BSP Parallel

Cod. TBSPSFA..

Pag. 4.80



**ADATTATORE A "T" INTERMEDIO
FEMMINA GIREVOLE**
Filetto Metrico Cilindrico
SWIVEL FEMALE EQUAL TEE
Thread Metric Parallel

Cod. TMSFA..

Pag. 4.81



**ADATTATORE A "T" LATERALE
MASCHIO/FEMMINA**
Filetto Gas Conico/Cilindrico
MALE/FEMALE STUD BARREL TEE
Thread BSP Taper/BSP Parallel

Cod. TLBSPTBSPMFA..

Pag. 4.82

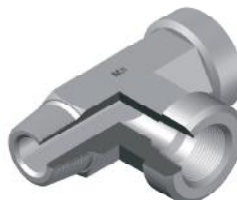

**ADATTATORE A "T" LATERALE
MASCHIO/FEMMINA**
Filetto NPT/Gas Cilindrico
MALE/FEMALE STUD BARREL TEE
Thread NPT/BSP Parallel

Cod. TLNPTBSPMFA..

Pag. 4.83



**ADATTATORE A "T" CENTRALE
MASCHIO/FEMMINA**
Filetto Gas Conico/Cilindrico
MALE/FEMALE STUD BRANCH TEE
Thread BSP Taper/BSP Parallel

Cod. TCBSPTBSPMFA..

Pag. 4.84



**ADATTATORE A "T" CENTRALE
MASCHIO/FEMMINA**
Filetto NPT/Gas Cilindrico
MALE/FEMALE STUD BRANCH TEE
Thread NPT/BSP Parallel

Cod. TCNPTBSPMFA..

Pag. 4.85

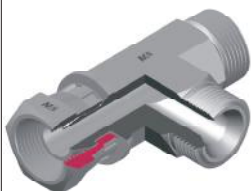

**ADATTATORE A "T" LATERALE
MASCHIO/FEMMINA GIREVOLE**
Filetto Gas Cilindrico
MALE/SWIVEL FEM. STUD BARREL TEE
Thread BSP Parallel

Cod. TLBSPMSFA..

Pag. 4.86

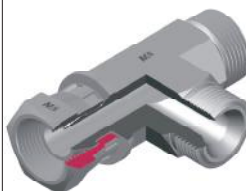

**ADATTATORE A "T" LATERALE
MASCHIO/FEMMINA GIREVOLE**
Filetto Metrico Cilindrico
MALE/SWIVEL FEM. STUD BARREL TEE
Thread Metric Parallel

Cod. TLMSFA..

Pag. 4.87



**ADATTATORE A "T" CENTRALE
MASCHIO/FEMMINA GIREVOLE**
Filetto Gas Cilindrico
MALE/SWIVEL FEM. STUD BRANCH TEE
Thread BSP Parallel

Cod. TCBSPMSFA..

Pag. 4.88



**ADATTATORE A "T" CENTRALE
MASCHIO/FEMMINA GIREVOLE**
Filetto Metrico Cilindrico
MALE/SWIVEL FEM. STUD BRANCH TEE
Thread Metric Parallel

Cod. TCMSFA..

Pag. 4.89



**ADATTATORE A CROCE
INTERMEDIO MASCHIO**
Filetto Gas Cilindrico
MALE EQUAL CROSS
Thread BSP Parallel

Cod. CRBSPMA..

Pag. 4.90



ADATTATORE A CROCE INT. FEMMINA
Filetto Gas Cilindrico
FEMALE EQUAL CROSS
Thread BSP Parallel

Cod. CRBSPFFA..

Pag. 4.91



TAPPO MASCHIO
Filetto Gas Cilindrico
MALE PLUG
Thread BSP Parallel

Cod. BSPMHP..

Pag. 4.92



TAPPO MASCHIO
Filetto Metrico Cilindrico
MALE PLUG
Thread Metric Parallel

Cod. MMHP..

Pag. 4.93



TAPPO MASCHIO
Filetto Gas Conico
MALE PLUG
Thread BSP Taper

Cod. MFHP..

Pag. 4.94



TAPPO MASCHIO
Filetto NPT
MALE PLUG
Thread NPT

Cod. NPTMHP..

Pag. 4.95



TAPPO FEMMINA FISSA
Filetto Gas Cilindrico
FIXED FEMALE PLUG
Thread BSP Parallel

Cod. BSPFHP..

Pag. 4.96



TAPPO FEMMINA FISSA
Filetto Metrico Cilindrico
FIXED FEMALE PLUG
Thread Metric Parallel

Cod. MFHP..

Pag. 4.97



TAPPO FEMMINA GIREVOLE
Filetto Gas Cilindrico
SWIVEL FEMALE PLUG
Thread BSP Parallel

Cod. BSPSFHP..

Pag. 4.98

INFORMAZIONE SUI PRODOTTI E DATI GENERALI *General Information*

I raccordi M.C.S. Hydraulics a norme ISO 8434-6/BSI 5200 sono raccordi di tipo meccanico.

Questi raccordi garantiscono un perfetto collegamento tra circuiti fluidodinamici, grazie alla tenuta metallo su metallo di due superfici coniche.

La perfetta conicità delle svasature garantisce un'indeformabilità dei componenti. grazie a queste sue caratteristiche, questo raccordo può essere impiegato ovunque vengano richieste prestazioni importanti.

M.C.S. Hydraulics couplings, realized according to ISO 8434-6/BSI 5200, are mechanical couplings.

They guarantee a perfect connection among fluid-dynamic circuits, thanks to metal to metal sealing between two taper parallel couplings.

The perfect taper of the countersinks guarantees inalterability to the components. Thanks to its features, this coupling can be used in every important performance.

ACCIAI IMPIEGATI

Steel Used on all Series

Componenti <i>Components</i>	Materiale - Material		Normativa <i>Reference Norm.</i>
Anello - Ring	X6CrNiMoTi17-12-2 (1,4571)	X2CrNiMoTi17-12-2 (1,4404)	DIN 17440
			EN 10088
Dado - Nut	X6CrNiMoTi17-12-2 (1,4571)	X2CrNiMoTi17-12-2 (1,4404)	DIN 17440
			EN 10088
Corpo da barra Straight Body	X6CrNiMoTi17-12-2 (1,4571)	X2CrNiMoTi17-12-2 (1,4404)	DIN 17440
			EN 10088
Corpo forgiato Forged Body	X6CrNiMoTi17-12-2 (1,4571)	X2CrNiMoTi17-12-2 (1,4404)	DIN 17440
			EN 10088

TRATTAMENTO DI FINITURA

Cleaning Process

Processo di Lavaggio ad Ultrasuoni:

Tutti gli articoli prodotti dalla M.C.S. Hydraulics sono sottoposti ad un trattamento di lavaggio ed asciugatura ad ultrasuoni.

La M.C.S. Hydraulics utilizza un sistema di vasche di lavaggio ad ultrasuoni doppia frequenza con moduli di risciacquo ed asciugatura; le bolle di cavitazione generate dalle onde ultrasoniche, consentono la rimozione di impurità e residui, come polvere, olii, grassi, trucioli e bave di lavorazione che aderiscano alla superficie metallica, senza peraltro intaccare il materiale stesso.

La tecnologia del lavaggio con ultrasuoni è molto diffusa come sistema per la pulizia di gioielleria, nonché di dispositivi medici ed odontoiatrici e viene sempre più spesso utilizzata per il lavaggio industriale: al termine di tale processo il raccordo si presenta brillante, completamente pulito e sterilizzato e soprattutto si presta ad essere utilizzato per svariate applicazioni particolari.

Ultrasonic Cleaning:

Each item produced by M.C.S. Hydraulics is subjected to an ultrasonic cleaning treatment. M.C.S. employs a cleaning device that uses Ultrasonic dual frequency waves and an appropriate cleaning

solvent, to clean each and every product.

Cavitation bubbles induced by the Ultrasound waves, act on a number of contaminants (Such as dirt, dust, grease etc.) adhering to metal.

This action also penetrates blind holes, cracks, and recesses; the intention is to remove all traces of contamination from surface .

Ultrasonics are used for industrial cleaning, but also in many medical and dental techniques: at the end of this process, fittings are bright, completely cleaned, sterilized and ready to be used even for very particular applications.

LUBRIFICAZIONE DEI COMPONENTI

Lubrication of the components

Per un corretto impiego dei nostri adattatori, è necessario eseguire una corretta lubrificazione su tutti i componenti da montare. Il lubrificante che vi consigliamo rappresenta l'ultima generazione di lubrificanti sintetici, esso è costituito da particelle ultrafini di lubrificanti solidi inorganici, il tutto in un composto sintetico che vi permetterà di impiegarlo con temperature e pressioni estremamente elevate, infatti, non solidificherà nell'impiego tra -34°C e 1204°C e garantirà una tenuta ottimale fino a 4730 kg/cm². Inoltre, è ecologico in quanto non contiene metalli pesanti velenosi che danneggerebbero il personale che vi entrerebbe in contatto. Il nostro ufficio tecnico sarà a vostra completa disposizione per qualsiasi informazione tecnica relativa al suddetto lubrificante.

It is necessary a correct lubrication of each component to use our adapters correctly. The lubricant we recommend belongs to the latest generation of synthetic lubricants; it is formed by a synthetic compound of very small particles of solid inorganic lubricants. It can be used at extremely high temperatures and pressures; in fact it does not solidify between -34°C and 1204°C and it guarantees an optimum seal until 4730 kg/cm². Besides, it is ecological because it does not contain noxious heavy metal which could be dangerous for people who come in contact with it. Our technical office will be at your disposal for further technical information.

TABELLA COMPATIBILITÀ FLUIDI

Fluids Compatibility table

Fluido	Acciaio Inox	NBR	VITON®	Fluido	Acciaio Inox	NBR	VITON®
Acetilene	O	N	N	Gas Naturale Non Trattato	O	N	N
Acetone	O	N	N	Gasolio	O	O	O
Acido Cloridrico	S	N	O	Glicerina	O	O	O
Acido Fosforico	N	N	S	Glicole	O	O	O
Acido Nitrico	S	N	S	Idrogeno	O	O	O
Acido Solforico	S	N	O	Iodio	O	S	O
Acqua	S	N	O	Kerosene	O	O	O
Acqua Distillata	O	O	O	Metano	O	O	O
Acqua Marina	S	O	O	Metanolo	O	O	O
Acqua Ossigenata	O	N	O	Nafta	O	O	O
Acquaragia	O	O	O	Neon	O	O	O
Ammoniaca Gassosa, Fredda	O	O	N	Olio	O	O	O
Ammoniaca Liquida	O	S	N	Olio da Riscaldamento	O	O	N
Anidride Carbonica	O	O	S	Olio dei Freni	O	N	O
Argo	O	O	O	Olio della Trasmissione	O	O	O
Aria	O	O	O	Olio Minerale	O	O	O
Aria compressa	O	O	O	Olio Minerale Naturale	O	S	O
ASTM-Oil, 1	O	O	O	Olio per Comandi Idraulici	O	O	O
ASTM-Oil, 2	O	O	O	Olio Vegetale	O	O	O
ASTM-Oil, 3	O	O	O	Ossido di Carbonio	O	O	N
Azoto	O	O	O	Ossigeno	O	N	O
Benzene	O	N	O	Ozono	O	N	O
Biossido di Zolfo	O	N	O	Pentano	O	O	O
Bisolfuro di Carbonio	O	N	O	Pentano Liquido	O	O	O
Butano	O	O	O	Propano	O	O	O
Cloro	O	N	O	Silicone	O	O	O
Elio	O	O	O	Stirene	O	S	O
Etano	O	O	N	Toluolo	O	N	S
Etere	O	O	N	Trielina	S	N	S
Gas Combustibile	O	O	S	Vapore	O	N	N
Gas Naturale	O	O	O	Xilolo	O	N	O

Legenda: O = Ottimo; S = Sufficiente; N = Non Raccomandato.
 Legend : O = Excellent ; S = Sufficient ; N = Not Recommended

VITON® è un marchio registrato dalla DuPont Dow Elastomers
 VITON® is a DuPont Dow Elastomers Trade Mark

TUBI IN ACCIAIO INOSSIDABILE CONSIGLIATI

Recommended Stainless Steel Tubes

Si consiglia l'uso di tubi in acciaio inossidabile calibrati e lucidati, trafilati a freddo senza saldatura, in AISI 316 Ti secondo la norma DIN 17458 o ASTM A269, con durezza massima sul diametro esterno di 85HRB. Le pressioni indicate nella tabella a seguire sono state rilevate in condizioni di carico costante e temperatura compresa tra i -20°C e i 120°C

The use of seamless stainless steel Aisi 316Ti (EN 1.4571) cold drawn, brightened tubes, according to DIN 17458 or ASTM A269, with maximum hardness on outer diameter of 85HRB is recommended. Pressure shown in the following table has been noticed in conditions of constant load and temperature between -20°C and 120°C.

Ø Tubo mm	Tolleranza mm	Spessore mm	Pressione DIN 2413-1 Statico bar	Peso Kg/m	Ø Tubo mm	Tolleranza mm	Spessore mm	Pressione DIN 2413-1 Statico bar	Peso Kg/m		
4	±0,1	0,5	326	0,048	18	±0,08	1,5*	245	0,619		
		1	544	0,076			2	326	0,801		
6	±0,1	1	406	0,125			2,5	409	0,971		
		1,5	572	0,169			3	426	1,128		
8	±0,1	2	721	0,200			20	±0,08	2**	294	0,902
		1	347	0,225					2,5	368	1,095
		1,5	449	0,244	3	389			1,277		
		5	572	0,301	3,5	444			1,446		
		2,5	686	0,344	4	498			1,602		
		1	294	0,225	22	±0,08			2**	267	1,001
10	±0,1	1,5	389	0,319	25	±0,08	2,5	334	1,220		
		2	498	0,401			3	401	1,427		
		2,5	601	0,469			2**	236	1,151		
		3	694	0,526			2,5	294	1,408		
12	±0,08	1*	245	0,275	28	±0,08	3	352	1,653		
		1,5	368	0,394			4	411	2,104		
		2	426	0,500			4,5	456	2,310		
		2,5	516	0,595			2**	210	1,301		
		3	601	0,676			2,5	263	1,596		
		3,5	679	0,745			3	315	1,878		
14	±0,08	1,5	315	0,469	30	±0,08	2**	175	1,402		
		2	420	0,601			2,5	245	1,721		
		2,5	452	0,720			3	294	2,028		
		3	529	0,826			4	392	2,604		
		3,5	601	0,920			2**	168	2,222		
15	±0,08	1,5	294	0,507	35	±0,15	2,5	210	2,034		
		2	392	0,651			3	252	2,403		
		3	498	0,902			4	336	3,104		
16	±0,08	1,5**	275	0,544	38	±0,15	3**	232	2,628		
		2	368	0,702			4	310	3,405		
		2,5	402	0,845			5	387	4,131		
		3	471	0,977			3**	210	2,929		
					42	±0,2	4	280	3,806		

* Per tubi a norma DIN 2353 utilizzare la boccia di rinforzo adeguata.

** Utilizzare solo con raccordi a norma SAE J514.

*For tubes according to DIN 2353 it is necessary to use a support sleeve.

**You must use them only with fittings according to SAEJ514.

GUARNIZIONI IMPIEGATE

Sealing Materials :

Le guarnizioni impiegate, possono essere sia in NBR ed hanno una temperatura di esercizio compresa tra i -35°C ed i 100°C e durezza 85±5 Shore, sia in VITON® se dovessero sostenere temperature di esercizio più elevate comprese tra i -25°C ed i 200°C e durezza 80±5 Shore. Tali prodotti devono essere stoccati secondo la norma DIN 7716 (Requisiti per l'immagazzinamento di prodotti in gomma e caucciù).

Seals used can be in NBR (Nitrile Rubber), so they have an operating temperature from -35°C to 100°C and hardness 85± 5 Shore, and in Viton® in case they are used for highest temperature from -25°C to 200°C and hardness 80±5 Shore. These products must be stored according to DIN 7716 (This is essential for the stocking of rubber products).

TEMPERATURE AMMESSE E RIDUZIONI DI PRESSIONE

Pressure reductions and Temperature

Acciaio inossidabile da -60°C a 200°C secondo ISO 8434.

La riduzione della pressione di esercizio sui raccordi in acciaio inossidabile 1.4571 deve essere applicata in funzione della temperatura di esercizio riscontrata, secondo la NORMA ISO 8434. In caso di sistema con più componenti i parametri devono essere calcolati sul componente più debole.

Stainless steel from -60°C to 200°C according to ISO 8434.

The reduction of the operating pressure on stainless steel fittings 14571 must be applied according to the operating temperature, in accordance with ISO 8434. For systems consisting of more components the parameters must be calculated on the weakest component.

<i>Tipo di acciaio impiegato</i> Type of Steel used	<i>Temperatura di esercizio</i> Operating temperature	<i>Riduzione della pressione di esercizio</i> Oper. Press.Reduc.
1,4571	≥ 50°C	-4%
1,4571	≥100°C	-11%
1,4571	≥200°C	-20%

RESPONSABILITÀ

Liability

PRESCRIZIONI DA RISPETTARE

Warning

- *Rispettare tutte le indicazioni di montaggio contenuto in questo catalogo.*
 - *Utilizzare per le connessioni, tubi di qualità come da «tabella tubi consigliati»*
 - *Sui tubi a pareti sottili applicare boccole di rinforzo.*
 - *Utilizzare solo componenti M.C.S. per le connessioni e non alterare il prodotto originale M.C.S. .*
 - *Lubrificare sempre tutti i componenti come indicato nelle istruzioni di montaggio.*
 - *Rispettare la pressioni e le temperature indicate nel catalogo.*
 - *Il non utilizzo delle suddette prescrizioni, oltre ad alterare la sicurezza funzionale dei nostri prodotti, esclude tutti i diritti di garanzia.*
- *Observe assembly instructions contained in this catalogue;*
 - *Observe Tube Recommendations (See page 5: Recommended stainless steel tubes);*
 - *In case of assembly with thin walled tubes, apply support sleeves;*
 - *For complete safety, use only M.C.S. components; do not alter/modify M.C.S.'s products;*
 - *Components must be lubricated as seen in the Assembly Instructions section;*
 - *Observe pressure and temperatures as indicated;*
 - *There is no functional safety of our products and no warranty rights without observing the above described instructions.*

RESPONSABILITÀ PRODOTTO

Product Liability

I prodotti M.C.S. sono garantiti esenti da difetti di lavorazione e di materiale. Tale garanzia verrà applicata al prodotto effettivamente difettoso che presenti non conformità o mal funzionamenti non riscontrabili al momento dell'acquisto, purché lo stesso sia utilizzato esattamente come riportato nelle nostre istruzioni di montaggio e comunque entro e non oltre sei mesi dalla data di acquisto del materiale.

M.C.S.'s products are guaranteed without manufacturing or material fault. This warranty will be applied to the product effectively faulty, which presents a bad functioning not showed at the moment of the purchase and only if it has been used as recommended in our assembly instructions and within six months after the purchase date.

COLLAUDO Testing

I raccordi M.C.S. sono costruiti rispettando integralmente la norma ISO 8434-2 di riferimento. Le pressioni riportate nel presente catalogo sono quelle massime consentite collaudate con un fattore di sicurezza 4:1 sia per le connessioni tubo-tubo, che per i terminali cilindrici con guarnizione incassata. Il fattore di sicurezza scende a 2.5:1 sui terminali cilindrici con tenuta in metallo su metallo e sui terminali a filettatura conica. Inoltre tutta la gamma di adattatori prodotta dalla M.C.S. Hydraulics è stata collaudata fino alla pressione di scoppio del tubo rigido. La M.C.S. Hydraulics S.r.l. dispone, per le prove interne, di un banco per prove in pressioni di tubi che consente di eseguire test di tenuta, scoppio ed a pressione pulsante fino a 4000 Bar; su richiesta è possibile effettuare il collaudo dei componenti ordinati ed ottenere il rilascio del certificato delle prove eseguite secondo la ISO 8434-5: è possibile infine richiedere che tali prove vengano eseguite alla presenza di ispettori di Enti Certificatori; tra i quali si citano (a titolo esemplificativo e non esaustivo): Rina, Lloyd's, Register, DNV etc.

M.C.S.'s Din compression couplings are completely manufactured in accordance with ISO 8434-2 standards.

Pressure values shown in this catalogue are those maximum allowed and tested considering the security factor 4:1, it is intended for tube to tube connections and parallel stud couplings with captive seal. The security factor is 2.5:1 for metal to metal sealing parallel and taper parallel threaded stud couplings. Besides, all couplings manufactured by M.C.S. Hydraulics have been tested up to tube burst pressure.

A test bench is available to provide in-house static, burst and pulsing pressure tests up to 4000 Bar. On request it is possible to test the components and to issue certificates according to ISO 8434-5.

It is also possible to have these tests performed in the presence of qualified inspectors: Rina, Lloyd's Register, DNV for instance.

COPPIE DI SERRAGGIO - Torque wrench

Raccordi su Tubazioni - Nut on Tube

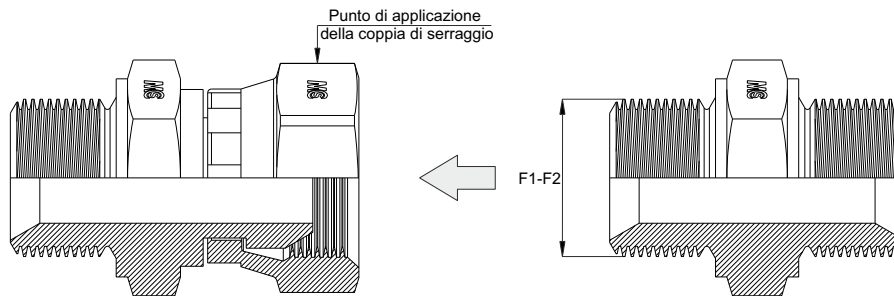

F1	N MAX (Nm)	F2	N MAX (Nm)	TUBO
1/8"	14	10x1	14	6
1/4"	20	12x1,5	20	8
3/8"	35	14x1,5	35	10
1/2"	60	16x1,5	60	12
5/8"	70	18x1,5	70	16
3/4"	110	22x1,5	110	18
1"	140	27x1,5	170	25
1" 1/4	190	33x2	290	32
1" 1/2	290	42x2	310	38

F1 - Filetto Gas Cilindrico - Thread BSP Parallel

F2 - Filetto Metrico Cilindrico - Thread Metric Parallel

COPPIE DI SERRAGGIO - Torque wrench

Raccordi Girevoli - Swivel Fittings

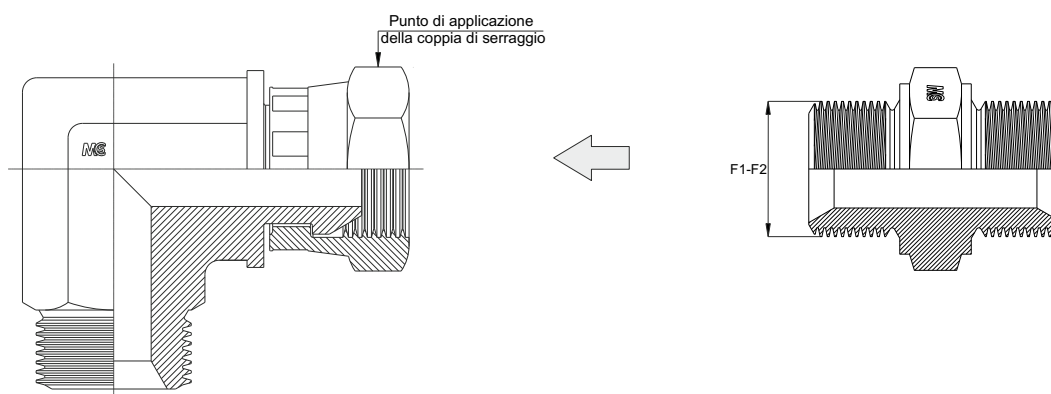

F1	N MAX (Nm)	F2	N MAX (Nm)
1/8"	10	10x1	10
1/4"	20	12x1,5	20
3/8"	35	14x1,5	35
1/2"	60	16x1,5	60
5/8"	70	18x1,5	70
3/4"	115	20x1,5	70
1"	140	22x1,5	115
1" 1/4	210	26x1,5	130
		27x1,5	140
		28x1,5	150
		30x1,5	190
		33x2	210

F1 - Filetto Gas Cilindrico - Thread BSP Parallel

F2 - Filetto Metrico Cilindrico - Thread Metric Parallel

COPPIE DI SERRAGGIO - Torque wrench

Filetto Gas Cilindrico *Filetto UNF/UN-2A*

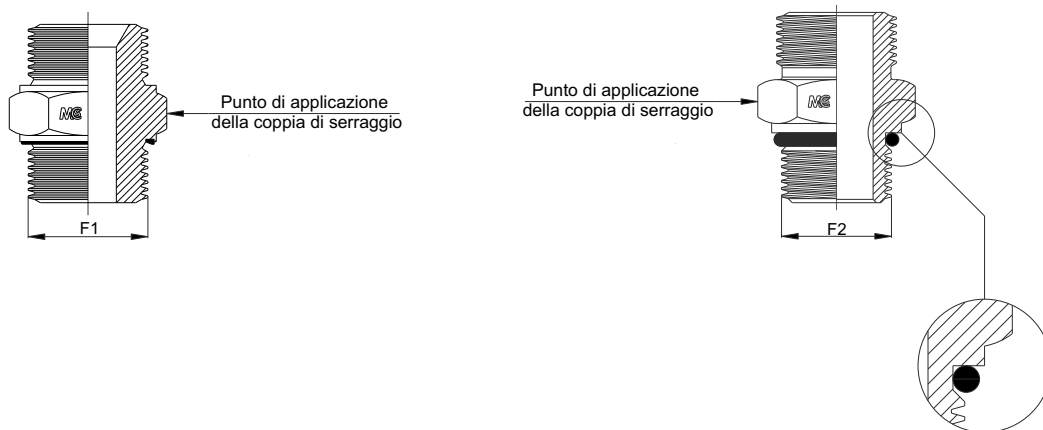

F1	N MAX (Nm)	F2	N MAX (Nm)
1/8"	20	7/16"	20
1/4"	45	1/2"	25
3/8"	70	9/16"	30
1/2"	85	3/4"	45
3/4"	170	7/8"	55
1"	330	1"1/16"	85
1"1/4"	430	1"5/16"	130
1"1/2"	510	1"5/8"	170

F1 - Filetto Gas Cilindrico - Thread BSP Parallel
 F2 - Filetto UNF/UN-2A - Thread UNF/UN-2A

COPPIE DI SERRAGGIO - Torque wrench

Filetto Metrico Cilindrico

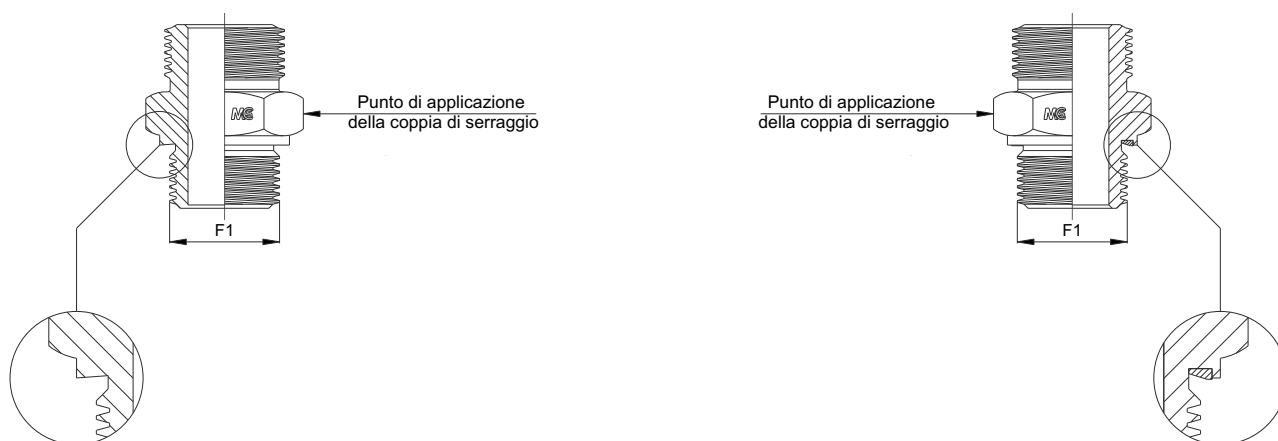

F1	N MAX (Nm)
10x1	20
12x1,5	30
14x1,5	45
16x1,5	55
18x1,5	80
20x1,5	-
22x1,5	120
27x1,5	170
33x2	330
42x2	-

F1 - Filetto Metrico Cilindrico - Thread Metric Parallel

SEDI E FILETTATURE BSP THREAD COUPLING - BSP THREAD

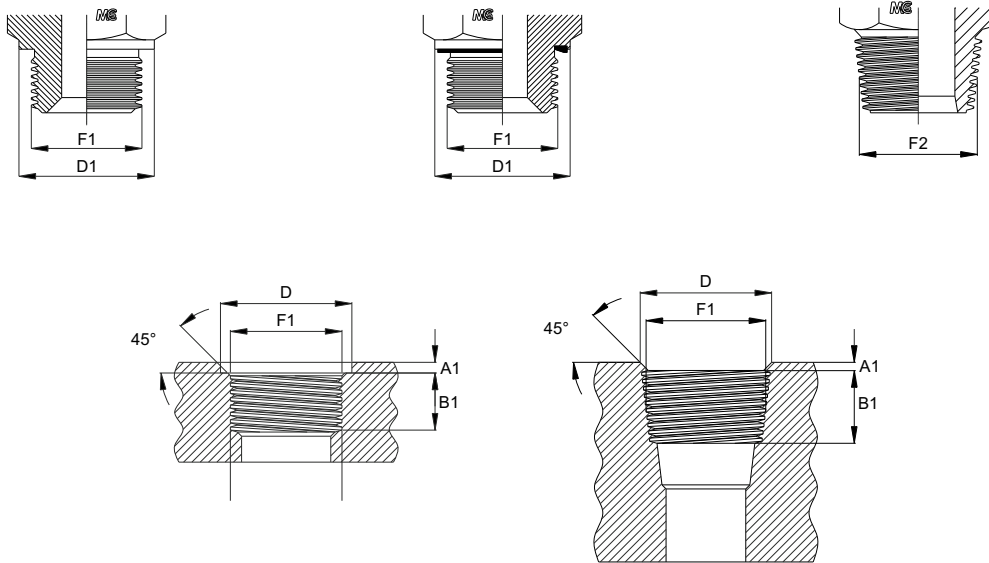

F1	F2	A1 MAX	B1 MIN	D	D1	D2	B2 MIN	TUBO	SERIE
1/8"	1/8"	1	8	15	14	14	5,5	6	L
1/4"	1/4"	1,5	12	19	18	18,9	8,5	8	L
1/4"	1/4"	1,5	12	19	18	18,9	8,5	10	L
3/8"	3/8"	1,5	12	23	22	22	8,5	12	L
1/2"	1/2"	2	12	27	26	26,9	10,5	15	L
1/2"	1/2"	2,5	14	27	26	26,9	10,5	18	L
3/4"	3/4"	2,5	16	33	32	32	13	22	L
1"	1"	2,5	18	40	39	39,9	16	28	L
1" 1/4	1" 1/4	2,5	20	50	49	49,9	17	35	L
1" 1/2	1" 1/2	2,5	22	56	55	55	17	42	L
1/4"	1/4"	1,5	12	19	18	18,9	8,5	6	S
1/4"	1/4"	1,5	12	19	18	18,9	8,5	8	S
3/8"	3/8"	1,5	12	23	22	22	8,5	10	S
3/8"	3/8"	2	12	23	22	22	8,5	12	S
1/2"	1/2"	2	14	27	26	26,9	10,5	14	S
1/2"	1/2"	2,5	14	27	26	26,9	10,5	16	S
3/4"	3/4"	2,5	16	33	32	32	13	20	S
1"	1"	2,5	18	40	39	39,9	16	25	S
1" 1/4	1" 1/4	2,5	20	50	49	49,9	17	30	S
1" 1/2	1" 1/2	2,5	22	56	55	55	17	38	S

F1 - Filetto Gas Cilindrico - Thread BSP Parallel
F2 - Filetto Gas Conico - Thread BSP Taper

SEDI E FILETTATURE METRICHE

THREAD COUPLING - METRIC THREAD

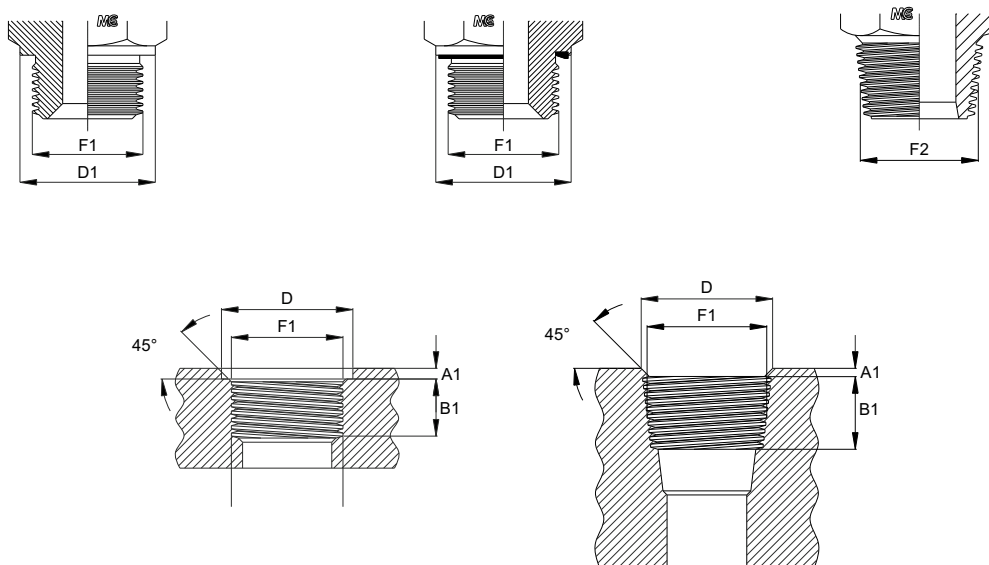

F1	F2	A1 MAX	B1 MIN	D	D1	D2	B2 MIN	TUBO	SERIE
10x1	10x1	1	8	15	14	14	5,5	6	L
12x1,5	12x1,5	1,5	12	18	17	17	8,5	8	L
14x1,5	14x1,5	1,5	12	20	19	19	8,5	10	L
16x1,5	16x1,5	1,5	12	22	21	21,9	8,5	12	L
18x1,5	18x1,5	2	12	24	23	23,9	8,5	15	L
22x1,5	22x1,5	2,5	14	28	27	27	10,5	18	L
26x1,5		2,5	16	32	31	31,9		22	L
33x2		2,5	18	40	39	39,9		28	L
42x2		2,5	20	50	49	49,9		35	L
48x2		2,5	22	56	55	55		42	L
12x1,5	12x1,5	1,5	12	18	17	17	8,5	6	S
14x1,5	14x1,5	1,5	12	20	19	19	8,5	8	S
16x1,5	16x1,5	1,5	12	22	21	21,9	8,5	10	S
18x1,5	18x1,5	2	12	24	23	23,9	8,5	12	S
20x1,5	20x1,5	2	14	26	25	25,9	10,5	14	S
22x1,5	22x1,5	2,5	14	28	27	27	10,5	16	S
27x2		2,5	16	33	32	32		20	S
33x2		2,5	18	40	39	39,9		25	S
42x2		2,5	20	50	49	49,9		30	S
48x2		2,5	22	56	55	55		38	S

F1 - Filetto Metrico Cilindrico - Thread Metric Parallel
 F2 - Filetto Metrico Conico - Thread Metric Taper

SEDI E FILETTATURE UNF/UN-2A THREAD COUPLING - UNF/UN-2A

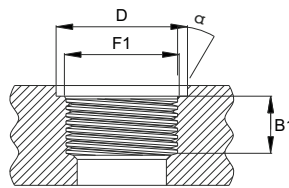
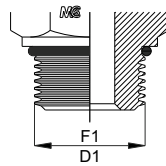

F1	A1 MAX	B1 MIN	D	D1	a
7/16"	1,6	11,5	21	15,8	12°
1/2"	1,6	11,5	23	16,2	12°
9/16"	1,6	12,7	25	17,7	12°
3/4"	2,4	14,3	30	23	15°
7/8"	2,4	16,7	34	27	15°
1" 1/16	2,4	19	41	32	15°
1" 5/16	3,2	19	49	38,1	15°
1" 5/8	3,2	19	58	48	15°

F1 - UNF/UN-2A

SEDI E FILETTATURE NPT THREAD COUPLING - NPT

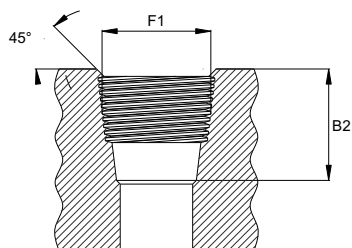
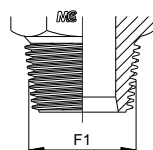

F1	B2 MIN
1/8"	1,6
1/4"	1,6
3/8"	1,6
1/2"	2,4
3/4"	2,4
1"	2,4
1" 1/4	3,2
1" 1/2	3,2

F1 - NPT

ADATTATORE DIRITTO MASCHIO

Filetto Gas Cilindrico

MALE STRAIGHT ADAPTOR

Thread BSP Parallel

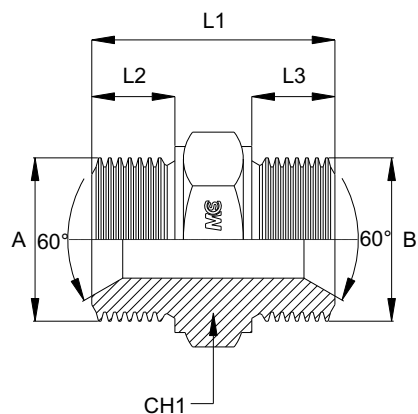

Bar W.P.	Codice Part Number	A	B	L1	L2	L3	CH1
400	BSPMA0202	1/8"	1/8"	25,0	8,0	8,0	14
	BSPMA0404	1/4"	1/4"	32,0	11,0	11,0	19
	BSPMA0606	3/8"	3/8"	35,0	12,0	12,0	22
350	BSPMA0808	1/2"	1/2"	39,0	14,0	14,0	27
	BSPMA1010	5/8"	5/8"	43,0	16,0	16,0	30
315	BSPMA1212	3/4"	3/4"	45,0	16,0	16,0	32
250	BSPMA1616	1"	1"	53,0	19,0	19,0	41
220	BSPMA2020	1" 1/4	1" 1/4	55,0	20,0	20,0	50
170	BSPMA2424	1" 1/2	1" 1/2	56,5	20,0	20,0	55
125	BSPMA3232	2"	2"	66,5	24,5	24,5	70
70	BSPMA4040	2,1/2"	2,1/2"	69,5	26,0	26,0	80

ADATTATORE DIRITTO MASCHIO - Sede Piana

Filetto Gas Cilindrico

MALE STRAIGHT ADAPTOR - Flat Seat

Thread BSP Parallel

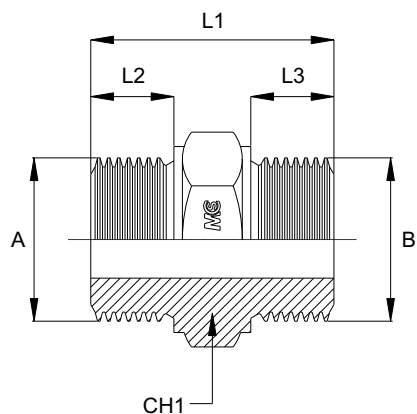

Bar W.P.	Codice Part Number	A	B	L1	L2	L3	CH1
400	BSPFSMA0202	1/8"	1/8"	25,0	8,0	8,0	14
	BSPFSMA0404	1/4"	1/4"	32,0	11,0	11,0	19
	BSPFSMA0606	3/8"	3/8"	35,0	12,0	12,0	22
350	BSPFSMA0808	1/2"	1/2"	39,0	14,0	14,0	27
	BSPFSMA1010	5/8"	5/8"	43,0	16,0	16,0	30
315	BSPFSMA1212	3/4"	3/4"	45,0	16,0	16,0	32
250	BSPFSMA1616	1"	1"	53,0	19,0	19,0	41
200	BSPFSMA2020	1" 1/4	1" 1/4	55,0	20,0	20,0	50
160	BSPFSMA2424	1" 1/2	1" 1/2	56,5	20,0	20,0	55
125	BSPFSMA3232	2"	2"	66,5	24,5	24,5	70

ADATTATORE MASCHIO DIRITTO CON GUARNIZIONE

Filetto Gas Cilindrico

MALE STRAIGHT ADAPTOR WITH CAPTIVE SEAL

Thread BSP Parallel

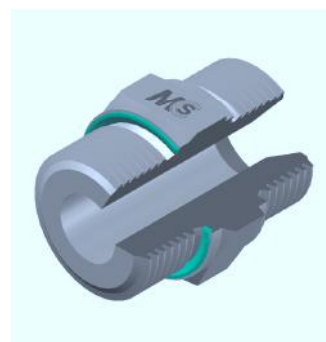
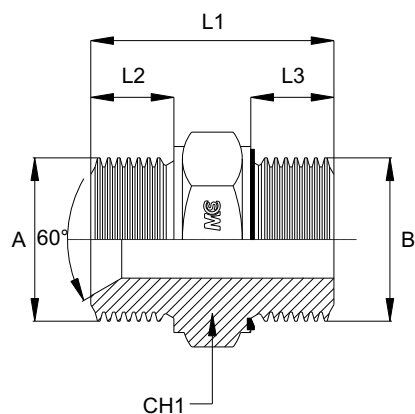

Bar W.P.	Codice Part Number	A	B	L1	L2	L3	CH1
400	BSPMA0202V	1/8"	1/8"	25,0	8,0	8,0	14
	BSPMA0404V	1/4"	1/4"	32,0	11,0	11,0	19
	BSPMA0606V	3/8"	3/8"	35,0	12,0	12,0	22
350	BSPMA0808V	1/2"	1/2"	39,0	14,0	14,0	27
	BSPMA1010V	5/8"	5/8"	43,0	16,0	16,0	30
315	BSPMA1212V	3/4"	3/4"	45,0	16,0	16,0	32
250	BSPMA1616V	1"	1"	53,0	19,0	19,0	41
220	BSPMA2020V	1" 1/4	1" 1/4	55,0	20,0	20,0	50
170	BSPMA2424V	1" 1/2	1" 1/2	56,5	20,0	20,0	55
125	BSPMA3232V	2"	2"	66,5	24,5	24,5	70
70	BSPMA4040V	2" 1/2	2" 1/2	69,5	26,0	26,0	80

NOTE: VITON® è un marchio registrato dalla DuPont Dow Elastomers
 NOTE: VITON® is a DuPont Dow Elastomers Trade Mark

ADATTATORE MASCHIO DIRITTO CON DOPPIA GUARNIZIONE

Filetto Gas Cilindrico

MALE STRAIGHT ADAPTOR WITH DOUBLE CAPTIVE SEAL

Thread BSP Parallel

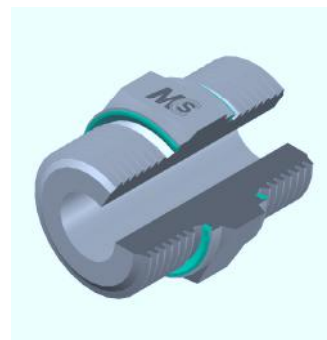
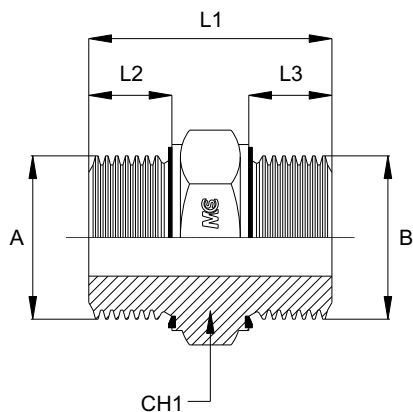

Bar W.P.	Codice Part Number	A	B	L1	L2	L3	CH1
400	BSPMA0202DV	1/8"	1/8"	25,0	8,0	8,0	14
	BSPMA0404DV	1/4"	1/4"	32,0	11,0	11,0	19
	BSPMA0606DV	3/8"	3/8"	35,0	12,0	12,0	22
350	BSPMA0808DV	1/2"	1/2"	39,0	14,0	14,0	27
	BSPMA1010DV	5/8"	5/8"	43,0	16,0	16,0	30
315	BSPMA1212DV	3/4"	3/4"	45,0	16,0	16,0	32
250	BSPMA1616DV	1"	1"	53,0	19,0	19,0	41
220	BSPMA2020DV	1" 1/4	1" 1/4	55,0	20,0	20,0	50
170	BSPMA2424DV	1" 1/2	1" 1/2	56,5	20,0	20,0	55
125	BSPMA3232DV	2"	2"	66,5	24,5	24,5	70
70	BSPMA4040DV	2" 1/2	2" 1/2	69,5	26,0	26,0	80

NOTE: VITON® è un marchio registrato dalla DuPont Dow Elastomers
 NOTE: VITON® is a DuPont Dow Elastomers Trade Mark

ADATTATORE MASCHIO DI RIDUZIONE

Filetto Gas Cilindrico

MALE STRAIGHT REDUCING ADAPTOR

Thread BSP Parallel

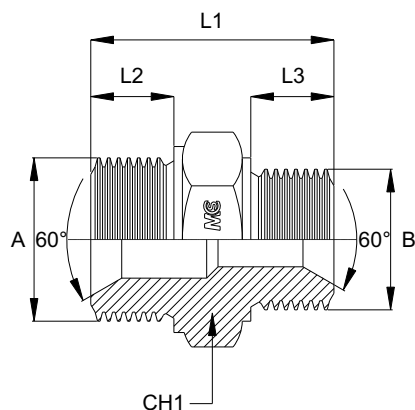

Bar W.P.	Codice Part Number	A	B	L1	L2	L3	CH1
400	BSPMRA0402	1/4"	1/8"	29,0	11,0	8,0	19
	BSPMRA0602	3/8"	1/8"	31,0	12,0	8,0	22
	BSPMRA0604	3/8"	1/4"	34,0	12,0	11,0	22
350	BSPMRA0802	1/2"	1/8"	33,0	14,0	8,0	27
	BSPMRA0804	1/2"	1/4"	36,0	14,0	11,0	27
	BSPMRA0806	1/2"	3/8"	38,0	14,0	12,0	27
	BSPMRA1006	5/8"	3/8"	39,0	16,0	12,0	30
315	BSPMRA1008	5/8"	1/2"	41,0	16,0	14,0	30
	BSPMRA1202	3/4"	1/8"	37,0	16,0	8,0	32
	BSPMRA1204	3/4"	1/4"	40,0	16,0	11,0	32
	BSPMRA1206	3/4"	3/8"	41,0	16,0	12,0	32
	BSPMRA1208	3/4"	1/2"	43,0	16,0	14,0	32
250	BSPMRA1210	3/4"	5/8"	45,0	16,0	16,0	32
	BSPMRA1604	1"	1/4"	44,5	19,0	11,0	41
	BSPMRA1606	1"	3/8"	45,5	19,0	12,0	41
	BSPMRA1608	1"	1/2"	47,5	19,0	14,0	41
	BSPMRA1610	1"	5/8"	49,5	19,0	16,0	41
220	BSPMRA1612	1"	3/4"	50,0	19,0	16,0	41
	BSPMRA2008	1" 1/4	1/2"	48,5	20,0	14,0	50
	BSPMRA2012	1" 1/4	3/4"	51,0	20,0	16,0	50
	BSPMRA2016	1" 1/4	1"	54,5	20,0	19,0	50
170	BSPMRA2408	1" 1/2	1/2"	50,5	20,0	14,0	55
	BSPMRA2412	1" 1/2	3/4"	52,5	20,0	16,0	55
	BSPMRA2416	1" 1/2	1"	55,8	20,0	19,0	55
	BSPMRA2420	1" 1/2	1" 1/4	56,5	20,0	20,0	55
125	BSPMRA3212	2"	3/4"	58,3	24,5	16,0	70
	BSPMRA3216	2"	1"	61,5	24,5	19,0	70
	BSPMRA3220	2"	1" 1/4	62,0	24,5	20,0	70
	BSPMRA3224	2"	1" 1/2	62,5	24,5	20,0	70
70	BSPMRA4032	2" 1/2	2"	68,0	26,0	24,5	80

ADATTATORE DIRITTO MASCHIO

Filetto Metrico Cilindrico

MALE STRAIGHT ADAPTOR

Thread Metric Parallel

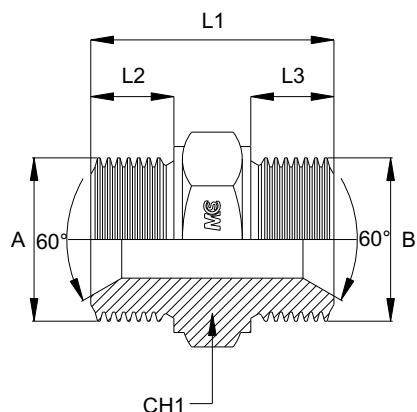

Bar W.P.	Codice Part Number	A	B	L1	L2	L3	CH1
400	MMA1212	12x1,5	12x1,5	34,0	12,0	12,0	17
	MMA1414	14x1,5	14x1,5	34,0	12,0	12,0	19
	MMA1616	16x1,5	16x1,5	34,0	12,0	12,0	22
	MMA1818	18x1,5	18x1,5	36,0	12,0	12,0	24
350	MMA2020	20x1,5	20x1,5	40,5	14,0	14,0	27
	MMA2222	22x1,5	22x1,5	41,0	14,0	14,0	27
315	MMA2424	24x1,5	24x1,5	41,0	14,0	14,0	30
	MMA2626	26x1,5	26x1,5	47,0	16,0	16,0	32
250	MMA2828	28x1,5	28x1,5	47,0	16,0	16,0	36
	MMA3030	30x1,5	30x1,5	48,0	16,0	16,0	36
200	MMA3838	38x1,5	38x1,5	50,0	16,0	16,0	46
160	MMA4545	45x1,5	45x1,5	52,0	16,0	16,0	55

Reducing Adaptor - Riduzioni

400	MMRA1214	12x1,5	14x1,5	34,0	12,0	12,0	19
	MMRA1416	14x1,5	16x1,5	34,0	12,0	12,0	22
	MMRA1418	14x1,5	18x1,5	36,0	12,0	12,0	24
	MMRA1618	16x1,5	18x1,5	36,0	12,0	12,0	24
350	MMRA1422	14x1,5	22x1,5	39,0	12,0	14,0	27
	MMRA1620	16x1,5	20x1,5	38,5	12,0	14,0	27
	MMRA1622	16x1,5	22x1,5	39,0	12,0	14,0	27
	MMRA1820	18x1,5	20x1,5	38,5	12,0	14,0	27
315	MMRA2022	20x1,5	22x1,5	41,0	14,0	14,0	27
	MMRA2226	22x1,5	26x1,5	44,5	14,0	16,0	32
250	MMRA2630	26x1,5	30x1,5	48,0	16,0	16,0	36
	MMRA3018	30x1,5	18x1,5	43,5	16,0	12,0	36
200	MMRA3038	30x1,5	38x1,5	50,0	16,0	16,0	46
160	MMRA3845	38x1,5	45x1,5	52,0	16,0	16,0	55

ADATTATORE DIRITTO MASCHIO

Filetto Gas Conico

MALE STRAIGHT ADAPTOR

Thread BSP Taper

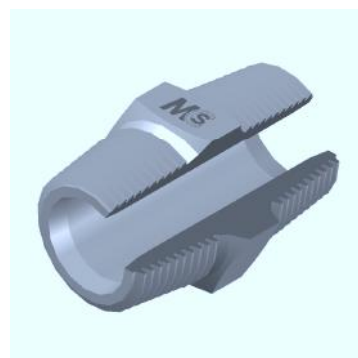
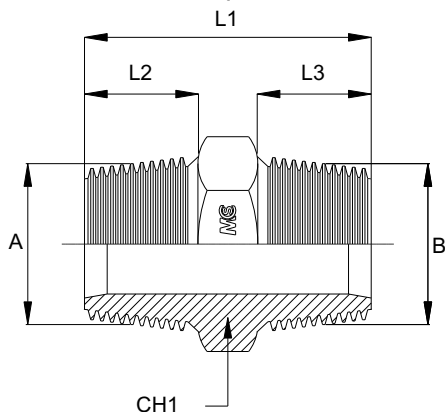

Bar W.P.	Codice Part Number	A	B	L1	L2	L3	CH1
350	BSPTMA0202	1/8"	1/8"	23,0	8,0	8,0	14
300	BSPTMA0404	1/4"	1/4"	32,0	13,0	13,0	14
280	BSPTMA0606	3/8"	3/8"	36,5	14,0	14,0	19
200	BSPTMA0808	1/2"	1/2"	43,5	17,0	17,0	22
	BSPTMA1212	3/4"	3/4"	45,0	17,5	17,5	27
120	BSPTMA1616	1"	1"	54,0	22,0	22,0	36
105	BSPTMA2020	1" 1/4	1" 1/4	59,0	24,0	24,0	46
	BSPTMA2424	1" 1/2	1" 1/2	59,5	24,0	24,0	50
70	BSPTMA3232	2"	2"	62,5	25,0	25,0	65

Reducing Adaptor - Riduzioni

300	BSPTMRA0402	1/4"	1/8"	28,0	13,0	8,0	14
280	BSPTMRA0604	3/8"	1/4"	34,5	14,0	13,0	19
200	BSPTMRA0802	1/2"	1/8"	33,5	17,0	8,0	22
	BSPTMRA0804	1/2"	1/4"	38,5	17,0	13,0	22
	BSPTMRA0806	1/2"	3/8"	40,0	17,0	14,0	22
	BSPTMRA1206	3/4"	3/8"	41,5	17,5	14,0	27
	BSPTMRA1208	3/4"	1/2"	45,0	17,5	17,0	27
120	BSPTMRA1608	1"	1/2"	50,0	22,0	17,0	36
	BSPTMRA1612	1"	3/4"	49,0	22,0	17,5	36
105	BSPTMRA2016	1" 1/4	1"	57,0	24,0	22,0	46
	BSPTMRA2420	1" 1/2	1" 1/4	59,5	24,0	24,0	50
70	BSPTMRA3224	2"	1" 1/2	64,5	25,0	24,0	65

ADATTATORE DIRITTO MASCHIO

Filetto NPT

MALE STRAIGHT ADAPTOR

Thread NPT

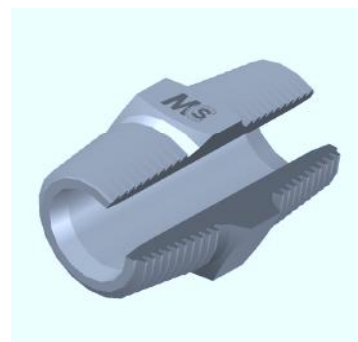
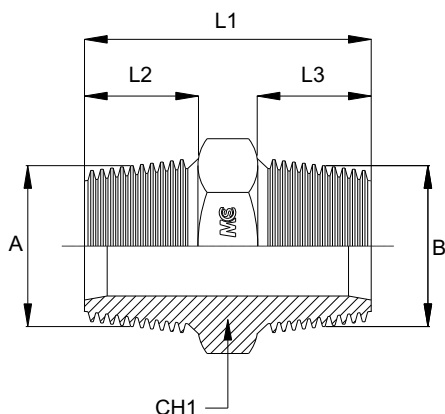

Bar W.P.	Codice Part Number	A	B	L1	L2	L3	CH1
350	NPTMA0202	1/8"	1/8"	27,0	10,0	10,0	14
	NPTMA0404	1/4"	1/4"	35,0	14,0	14,0	14
250	NPTMA0606	3/8"	3/8"	36,5	14,0	14,0	19
225	NPTMA0808	1/2"	1/2"	46,0	19,0	19,0	22
200	NPTMA1212	3/4"	3/4"	48,0	19,0	19,0	27
160	NPTMA1616	1"	1"	58,0	24,0	24,0	36
	NPTMA2020	1"1/4	1"1/4	60,5	24,5	24,5	46
	NPTMA2424	1"1/2	1"1/2	61,0	25,0	25,0	50
100	NPTMA3232	2"	2"	65,0	26,0	26,0	65

Reducing Adaptor - Riduzioni

350	NPTMRA0402	1/4"	1/8"	31,0	14,0	10,0	14
250	NPTMRA0602	3/8"	1/8"	32,5	14,0	10,0	19
	NPTMRA0604	3/8"	1/4"	36,5	14,0	14,0	19
225	NPTMRA0802	1/2"	1/8"	38,5	19,0	10,0	22
	NPTMRA0804	1/2"	1/4"	42,5	19,0	14,0	22
	NPTMRA0806	1/2"	3/8"	41,0	19,0	14,0	22
200	NPTMRA1206	3/4"	3/8"	41,5	19,0	14,0	27
	NPTMRA1208	3/4"	1/2"	48,0	19,0	19,0	27
160	NPTMRA1608	1"	1/2"	49,0	19,0	19,0	36
	NPTMRA1612	1"	3/4"	49,0	19,0	19,0	36
	NPTMRA2016	1"1/4	1"	60,0	24,5	19,0	46
	NPTMRA2420	1"1/2	1"1/4	61,0	25,0	24,5	50
100	NPTMRA3224	2"	1"1/2	66,5	26,0	25,0	65

ADATTATORE DIRITTO MASCHIO

Filetto Gas Cilindrico/Metrico Cilindrico

MALE STRAIGHT ADAPTOR

Thread BSP Parallel/Metric Parallel

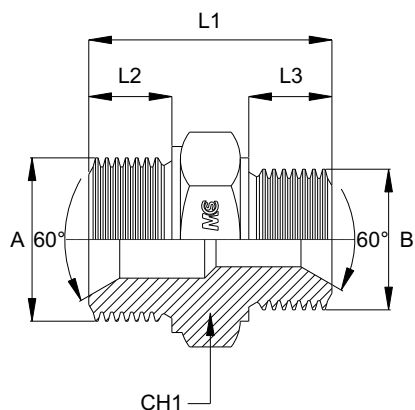

Bar W.P.	Codice Part Number	A	B	L1	L2	L3	CH1
400	MBSPMA1204	12x1,5	1/4"	32,0	11,0	11,0	19
	MBSPMA1404	14x1,5	1/4"	33,0	12,0	11,0	19
	MBSPMA1606	16x1,5	3/8"	35,0	12,0	12,0	22
350	MBSPMA1608	16x1,5	1/2"	35,5	12,0	14,0	27
400	MBSPMA1806	18x1,5	3/8"	36,0	12,0	12,0	24
350	MBSPMA1808	18x1,5	1/2"	37,0	12,0	14,0	27
	MBSPMA2006	20x1,5	3/8"	38,5	14,0	12,0	27
	MBSPMA2008	20x1,5	1/2"	40,5	14,0	14,0	27
	MBSPMA2204	22x1,5	1/4"	38,0	14,0	11,0	27
	MBSPMA2206	22x1,5	3/8"	39,0	14,0	12,0	27
315	MBSPMA2208	22x1,5	1/2"	41,0	14,0	14,0	27
	MBSPMA2408	24x1,5	1/2"	41,0	14,0	14,0	27
	MBSPMA2412	24x1,5	3/4"	43,5	14,0	16,0	32
250	MBSPMA2612	26x1,5	3/4"	47,0	16,0	16,0	32
	MBSPMA3012	30x1,5	3/4"	48,0	16,0	16,0	36
200	MBSPMA3016	30x1,5	1"	50,0	16,0	19,0	41
	MBSPMA3816	38x1,5	1"	53,0	16,0	19,0	46
160	MBSPMA3820	38x1,5	1" 1/4	54,0	16,0	20,0	50
	MBSPMA4520	45x1,5	1" 1/4	56,0	16,0	20,0	55
	MBSPMA4524	45x1,5	1" 1/2	56,0	16,0	20,0	55
-	MBSPMA5224	52x1,5	1" 1/2	-	-	20,0	-
-	MBSPMA6532	65x2,0	2"	-	-	24,5	-

ADATTATORE MASCHIO DIRITTO

Filetto Gas Cilindrico/Conico

MALE STRAIGHT ADAPTOR

Thread BSP Parallel/BSP Taper

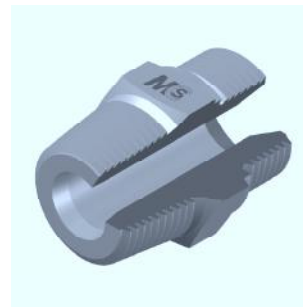
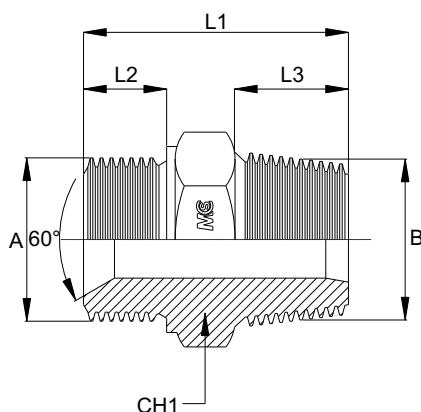

Bar W.P.	Codice Part Number	A	B	L1	L2	L3	CH1
350	BSPBSPTMA0202	1/8"	1/8"	24,5	8,0	8,0	14
300	BSPBSPTMA0404	1/4"	1/4"	32,0	11,0	12,5	19
280	BSPBSPTMA0606	3/8"	3/8"	35,5	12,0	13,9	22
200	BSPBSPTMA0808	1/2"	1/2"	40,5	14,0	17,0	27
	BSPBSPTMA1212	3/4"	3/4"	45,0	16,0	17,5	32
120	BSPBSPTMA1616	1"	1"	54,5	19,0	22,0	41
105	BSPBSPTMA2020	1" 1/4	1" 1/4	57,0	20,0	24,0	50
	BSPBSPTMA2424	1" 1/2	1" 1/2	58,0	20,0	24,0	55
70	BSPBSPTMA3232	2"	2"	65,0	24,5	25,0	70
*	BSPBSPTMA4040	2" 1/2	2" 1/2	74,0	26,0	33,0	80

Reducing Adaptor - Riduzioni

300	BSPBSPTMRA0204	1/8"	1/4"	29,5	8,0	13,0	19
280	BSPBSPTMRA0206	1/8"	3/8"	32,0	8,0	13,9	19
300	BSPBSPTMRA0402	1/4"	1/8"	27,5	11,0	8,0	19
280	BSPBSPTMRA0406	1/4"	3/8"	35,0	11,0	14,0	19
200	BSPBSPTMRA0408	1/4"	1/2"	39,0	11,0	17,0	22
280	BSPBSPTMRA0604	3/8"	1/4"	34,0	12,0	12,5	22
200	BSPBSPTMRA0608	3/8"	1/2"	40,0	12,0	17,0	22
	BSPBSPTMRA0612	3/8"	3/4"	41,0	12,0	17,5	27
	BSPBSPTMRA0802	1/2"	1/8"	32,5	14,0	8,0	27
	BSPBSPTMRA0804	1/2"	1/4"	36,5	14,0	13,0	22
	BSPBSPTMRA0806	1/2"	3/8"	37,5	14,0	14,0	27
	BSPBSPTMRA0812	1/2"	3/4"	41,0	14,0	17,5	27
	BSPBSPTMRA1206	3/4"	3/8"	41,0	16,0	14,0	32
120	BSPBSPTMRA1208	3/4"	1/2"	44,5	16,0	17,0	32
	BSPBSPTMRA1216	3/4"	1"	51,0	16,0	22,0	36
105	BSPBSPTMRA1612	1"	3/4"	49,0	19,0	17,5	41
	BSPBSPTMRA1620	1"	1" 1/4	56,0	19,0	24,0	46
	BSPBSPTMRA2016	1" 1/4	1"	55,0	20,0	22,0	50
	BSPBSPTMRA2024	1" 1/4	1" 1/2	58,0	20,0	24,0	50
70	BSPBSPTMRA2420	1" 1/2	1" 1/4	58,5	20,0	24,0	55
	BSPBSPTMRA2432	1" 1/2	2"	61,0	20,0	25,0	70
	BSPBSPTMRA3224	2"	1" 1/2	64,0	24,5	24,0	70

ADATTATORE MASCHIO DIRITTO

Filetto Gas Cilindrico/NPT

MALE STRAIGHT ADAPTOR

Thread BSP Parallel/NPT

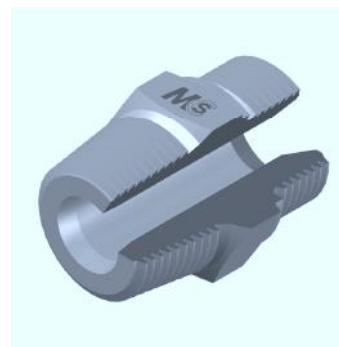
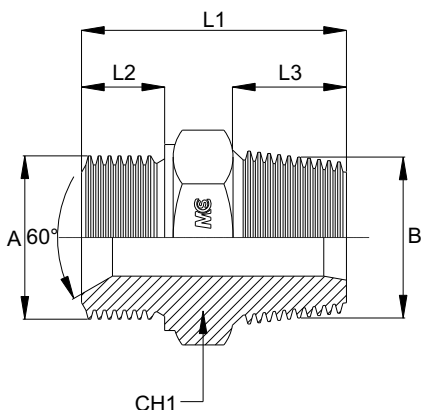

Bar W.P.	Codice Part Number	A	B	L1	L2	L3	CH1
350	BSPNPTMA0202	1/8"	1/8"	26,5	8,0	10,0	14
300	BSPNPTMA0404	1/4"	1/4"	33,5	11,0	14,0	19
280	BSPNPTMA0606	3/8"	3/8"	35,5	12,0	14,0	22
200	BSPNPTMA0808	1/2"	1/2"	42,5	14,0	19,0	27
	BSPNPTMA1212	3/4"	3/4"	46,0	16,0	19,0	32
120	BSPNPTMA1616	1"	1"	56,0	19,0	24,0	41
105	BSPNPTMA2020	1" 1/4	1" 1/4	57,5	20,0	24,5	50
	BSPNPTMA2424	1" 1/2	1" 1/2	59,5	20,0	25,0	55
70	BSPNPTMA3232	2"	2"	66,0	24,5	26,0	70

Reducing Adaptor - Riduzioni

300	BSPNPTMRA0204	1/8"	1/4"	30,5	8,0	14,0	14
	BSPNPTMRA0402	1/4"	1/8"	29,5	11,0	10,0	19
280	BSPNPTMRA0406	1/4"	3/8"	34,5	11,0	14,0	19
200	BSPNPTMRA0408	1/4"	1/2"	41,0	11,0	19,0	22
300	BSPNPTMRA0604	3/8"	1/4"	35,5	12,0	14,0	22
200	BSPNPTMRA0608	3/8"	1/2"	42,0	12,0	19,0	22
	BSPNPTMRA0612	3/8"	3/4"	41,0	12,0	19,0	27
	BSPNPTMRA0804	1/2"	1/4"	37,5	14,0	14,0	27
	BSPNPTMRA0806	1/2"	3/8"	37,5	14,0	14,0	27
	BSPNPTMRA0812	1/2"	3/4"	43,0	14,0	19,0	27
	BSPNPTMRA1206	3/4"	3/8"	41,0	16,0	14,0	32
120	BSPNPTMRA1208	3/4"	1/2"	46,0	16,0	19,0	32
120	BSPNPTMRA1216	3/4"	1"	52,0	16,0	24,0	36
105	BSPNPTMRA1224	3/4"	1" 1/2	54,5	16,0	25,0	50
120	BSPNPTMRA1612	1"	3/4"	54,0	19,0	19,0	41
105	BSPNPTMRA1620	1"	1" 1/4	57,0	19,0	24,5	46
	BSPNPTMRA2016	1" 1/4	1"	56,0	20,0	19,0	50
	BSPNPTMRA2024	1" 1/4	1" 1/2	52,5	20,0	25,0	55
	BSPNPTMRA2420	1" 1/2	1" 1/4	59,5	20,0	24,5	55
70	BSPNPTMRA2432	1" 1/2	2"	61,5	20,0	26,0	65
	BSPNPTMRA3224	2"	1" 1/2	65,0	24,5	25,0	70

ADATTATORE DIRITTO MASCHIO

Filetto Gas Conico/NPT

MALE STRAIGHT ADAPTOR

Thread BSP Taper/NPT

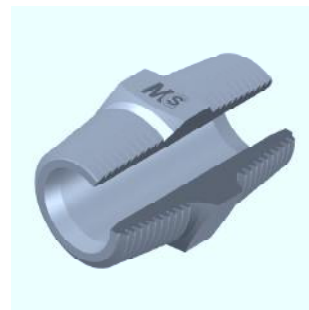
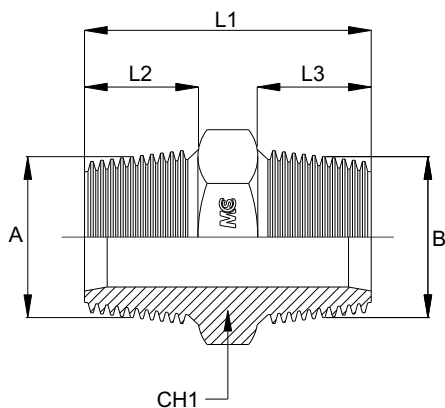

Bar W.P.	Codice Part Number	A	B	L1	L2	L3	CH1
350	BSPTNPTMA0202	1/8"	1/8"	25,0	8,0	10,0	14
300	BSPTNPTMA0404	1/4"	1/4"	34,0	13,0	14,0	14
250	BSPTNPTMA0606	3/8"	3/8"	36,0	14,0	14,0	19
200	BSPTNPTMA0808	1/2"	1/2"	46,5	17,0	19,0	22
	BSPTNPTMA1212	3/4"	3/4"	46,0	17,5	19,0	27
120	BSPTNPTMA1616	1"	1"	57,0	22,0	24,0	36
105	BSPTNPTMA2020	1" 1/4	1" 1/4	60,0	24,0	24,5	46
	BSPTNPTMA2424	1" 1/2	1" 1/2	60,0	24,0	25,0	50
70	BSPTNPTMA3232	2"	2"	66,5	25,0	26,0	65

PASSAPARETE MASCHIO CON DADO

Filetto Gas Cilindrico

BULKHEAD UNION (WITH NUT)

Thread BSP Parallel

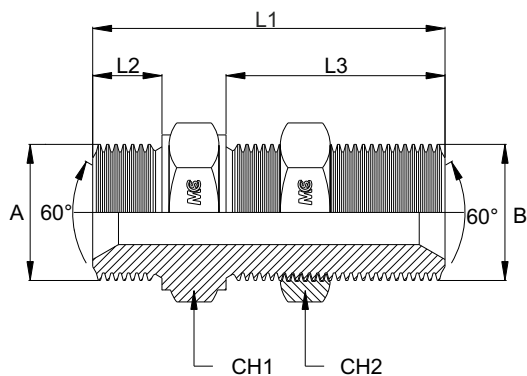

Bar W.P.	Codice Part Number	A	B	L1	L2	L3	CH1	CH2
400	BBSPMA02	1/8"	1/8"	44,0	8,0	27,0	14	17
	BBSPMA04	1/4"	1/4"	50,0	11,0	28,0	19	19
	BBSPMA06	3/8"	3/8"	54,0	12,0	31,0	22	22
350	BBSPMA08	1/2"	1/2"	61,5	14,0	35,0	27	27
	BBSPMA10	5/8"	5/8"	66,0	16,0	38,0	30	30
315	BBSPMA12	3/4"	3/4"	66,0	16,0	38,0	32	32
250	BBSPMA16	1"	1"	72,0	19,0	41,0	41	41
220	BBSPMA20	1" 1/4	1" 1/4	79,0	20,0	45,0	50	50
170	BBSPMA24	1" 1/2	1" 1/2	86,7	20,0	52,5	55	55
125	BBSPMA32	2"	2"	93,0	24,5	52,5	70	70

ADATTATORE DIRITTO FEMMINA

Filetto Gas Cilindrico

FEMALE UNION

Thread BSP Parallel

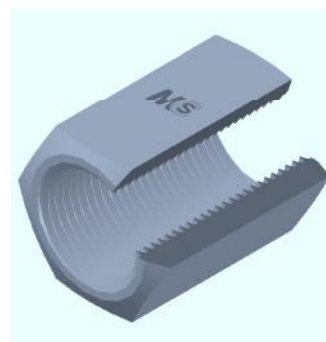
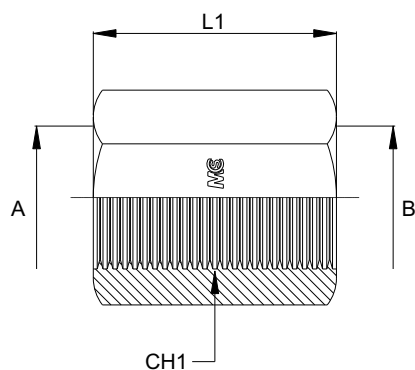

Bar W.P.	Codice Part Number	A	B	L1	CH1
400	BSPFFA0202	1/8"	1/8"	25,0	17
	BSPFFA0404	1/4"	1/4"	26,0	19
	BSPFFA0606	3/8"	3/8"	31,0	22
350	BSPFFA0808	1/2"	1/2"	34,0	27
	BSPFFA1010	5/8"	5/8"	44,0	30
315	BSPFFA1212	3/4"	3/4"	34,5	32
250	BSPFFA1616	1"	1"	48,0	38
200	BSPFFA2020	1"1/4	1"1/4	47,0	50
160	BSPFFA2424	1"1/2	1"1/2	51,0	55
125	BSPFFA3232	2"	2"	58,0	70

Reducing Adaptor - Riduzioni

400	BSPFFRA0402	1/4"	1/8"	26,0	19
	BSPFFRA0602	3/8"	1/8"	30,0	22
	BSPFFRA0604	3/8"	1/4"	31,0	22
350	BSPFFRA0804	1/2"	1/4"	34,0	27
	BSPFFRA0806	1/2"	3/8"	34,0	27
	BSPFFRA1006	5/8"	3/8"	37,0	30
315	BSPFFRA1206	3/4"	3/8"	35,0	32
	BSPFFRA1208	3/4"	1/2"	35,0	32
250	BSPFFRA1606	1"	3/8"	39,0	38
	BSPFFRA1608	1"	1/2"	43,0	38
	BSPFFRA1612	1"	3/4"	43,0	38
200	BSPFFRA2016	1"1/4	1"	47,0	50
160	BSPFFRA2420	1"1/2	1"1/4	50,0	55
125	BSPFFRA3224	2"	1"1/2	57,0	70

ADATTATORE DIRITTO FEMMINA

Filetto Metrico Cilindrico

FEMALE UNION

Thread Metric Parallel

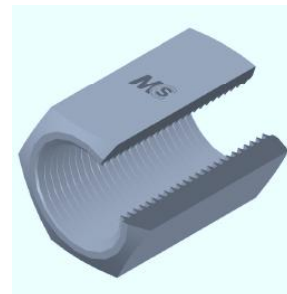
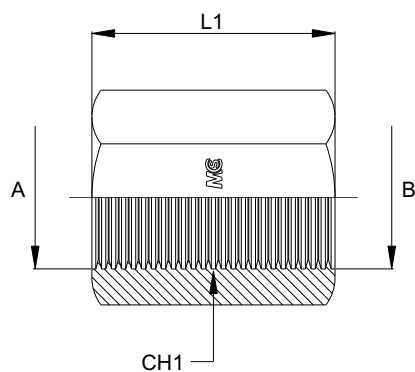

Bar W.P.	Codice Part Number	A	L1	L2	CH1
350	MFFA101	10x1,0	20,0	7,0	14
	MFFA1415	14x1,5	30,0	12,0	19
250	MFFA1615	16x1,5	30,0	12,0	24
225	MFFA2215	22x1,5	38,0	15,0	27
200	MFFA272	27x2,0	40,0	15,0	36
	MFFA332	33x2,0	48,0	19,0	38
160	MFFA422	42x2,0	50,0	19,0	55
	MFFA482	48x2,0	50,0	18,0	60

ADATTATORE DIRITTO FEMMINA

Filetto Gas Conico

FEMALE UNION

Thread BSP Taper

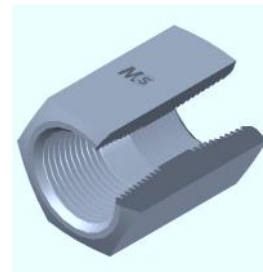
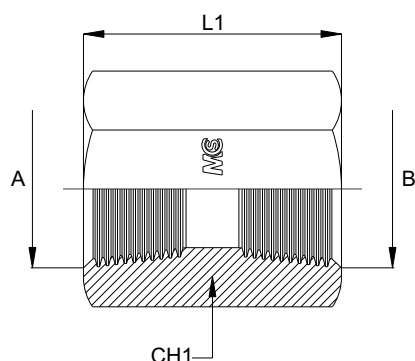

Bar W.P.	Codice Part Number	A	B	L1	CH1
350	BSPTFFA0202	1/8"	1/8"	24,0	17
300	BSPTFFA0404	1/4"	1/4"	32,0	19
280	BSPTFFA0606	3/8"	3/8"	32,0	22
200	BSPTFFA0808	1/2"	1/2"	40,0	27
	BSPTFFA1212	3/4"	3/4"	42,0	32
120	BSPTFFA1616	1"	1"	49,0	38
105	BSPTFFA2020	1" 1/4	1" 1/4	60,0	50
	BSPTFFA2424	1" 1/2	1" 1/2	60,0	55

Reducing Adaptor - Riduzioni

300	BSPTFFRA0204	1/8"	1/4"	28,0	19
	BSPTFFRA0206	1/8"	3/8"	28,0	22
280	BSPTFFRA0406	1/4"	3/8"	32,0	22
	BSPTFFRA0408	1/4"	1/2"	36,0	27
200	BSPTFFRA0412	1/4"	3/4"	37,0	32
	BSPTFFRA0608	3/8"	1/2"	36,0	27
	BSPTFFRA0812	1/2"	3/4"	41,0	32

ADATTATORE DIRITTO FEMMINA

Filetto NPT

FEMALE UNION

Thread NPT

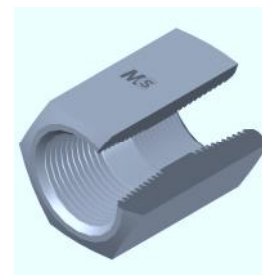
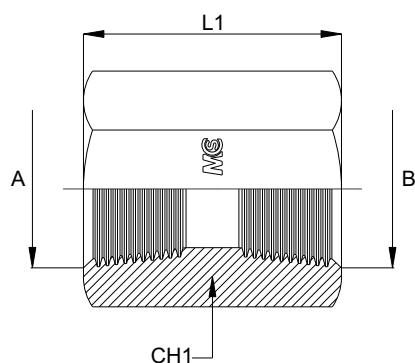

Bar W.P.	Codice Part Number	A	B	L1	CH1
350	NPTFFA0202	1/8"	1/8"	24,0	17
	NPTFFA0404	1/4"	1/4"	32,0	19
250	NPTFFA0606	3/8"	3/8"	32,0	22
225	NPTFFA0808	1/2"	1/2"	40,0	27
200	NPTFFA1212	3/4"	3/4"	46,0	32
160	NPTFFA1616	1"	1"	52,0	38
	NPTFFA2020	1"1/4	1"1/4	60,0	50
	NPTFFA2424	1"1/2	1"1/2	60,0	55
Reducing Adaptor - Riduzioni					
350	NPTFFRA0204	1/8"	1/4"	28,0	19
250	NPTFFRA0206	1/8"	3/8"	28,0	22
	NPTFFRA0406	1/4"	3/8"	32,0	22
225	NPTFFRA0408	1/4"	1/2"	37,0	27
200	NPTFFRA0412	1/4"	3/4"	37,0	32
225	NPTFFRA0608	3/8"	1/2"	37,0	27
200	NPTFFRA0812	1/2"	3/4"	42,0	32

ADATTATORE FEMMINA/FEMMINA GIREVOLE

Filetto Gas Cilindrico

FEMALE SWIVEL ADAPTOR

Thread BSP Parallel

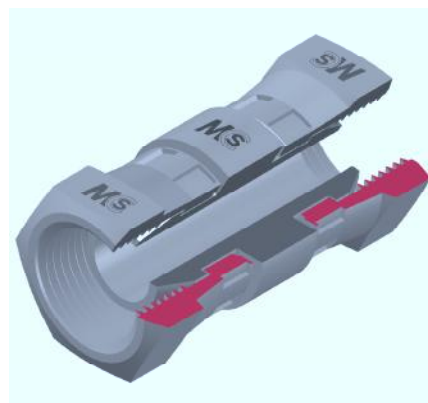
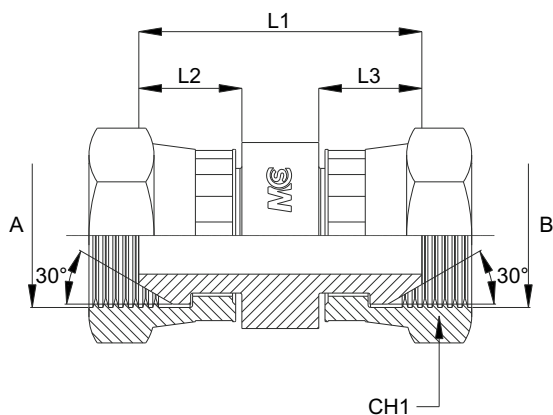

Bar W.P.	Codice Part Number	A	B	L1	L2	L3	CH1
400	BSPSFA0202	1/8"	1/8"	22,0	10,0	10,0	17
	BSPSFA0404	1/4"	1/4"	22,0	9,7	9,7	19
	BSPSFA0606	3/8"	3/8"	27,1	12,3	12,3	22
350	BSPSFA0808	1/2"	1/2"	32,5	14,5	14,5	27
315	BSPSFA1212	3/4"	3/4"	36,0	16,0	16,0	32
250	BSPSFA1616	1"	1"	37,6	16,8	16,8	38
200	BSPSFA2020	1"1/4	1"1/4	38,0	16,5	16,5	50
160	BSPSFA2424	1"1/2	1"1/2	45,0	20,5	20,5	55

PROLUNGA DIRITTA MASCHIO/FEMMINA

Filetto Gas Cilindrico

MALE/FEMALE CONNECTOR

Thread BSP Parallel

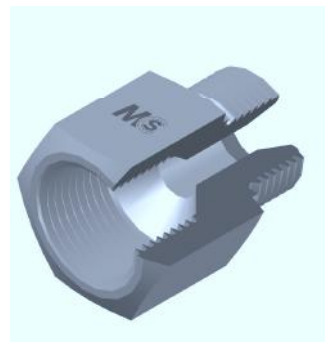
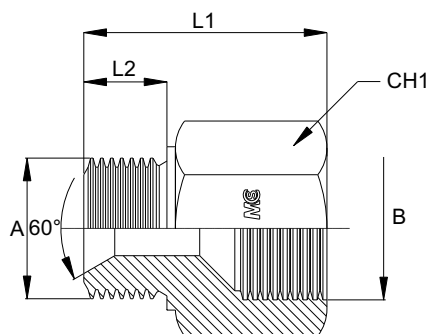

Bar W.P.	Codice Part Number	A	B	L1	L2	CH1
400	BSPMFFA0202	1/8"	1/8"	28,0	8,0	14
	BSPMFFA0204	1/8"	1/4"	29,0	8,0	19
	BSPMFFA0206	1/8"	3/8"	31,0	8,0	22
	BSPMFFA0402	1/4"	1/8"	31,0	11,0	19
	BSPMFFA0404	1/4"	1/4"	32,0	11,0	19
	BSPMFFA0406	1/4"	3/8"	32,0	11,0	22
350	BSPMFFA0408	1/4"	1/2"	36,0	11,0	27
250	BSPMFFA0416	1/4"	1"	43,5	11,0	38
400	BSPMFFA0604	3/8"	1/4"	35,0	12,0	22
	BSPMFFA0606	3/8"	3/8"	35,0	12,0	22
350	BSPMFFA0608	3/8"	1/2"	37,0	12,0	27
250	BSPMFFA0616	3/8"	1"	44,5	12,0	38
350	BSPMFFA0804	1/2"	1/4"	39,0	14,0	27
	BSPMFFA0806	1/2"	3/8"	38,0	14,0	27
	BSPMFFA0808	1/2"	1/2"	39,0	14,0	27
315	BSPMFFA0812	1/2"	3/4"	42,5	14,0	32
	BSPMFFA1204	3/4"	1/4"	37,5	16,0	32
	BSPMFFA1206	3/4"	3/8"	39,5	16,0	32
	BSPMFFA1208	3/4"	1/2"	41,0	16,0	32
	BSPMFFA1212	3/4"	3/4"	45,0	16,0	32
250	BSPMFFA1216	3/4"	1"	49,0	16,0	38
125	BSPMFFA1232	3/4"	2"	54,0	16,0	70
250	BSPMFFA1606	1"	3/8"	50,5	19,0	41
	BSPMFFA1608	1"	1/2"	52,5	19,0	41
	BSPMFFA1612	1"	3/4"	52,5	19,0	41
	BSPMFFA1616	1"	1"	53,0	19,0	41
200	BSPMFFA1620	1"	1"1/4"	56,5	19,0	50
160	BSPMFFA1624	1"	1"1/2"	54,0	19,0	55
200	BSPMFFA2012	1"1/4"	3/4"	53,0	20,0	50
	BSPMFFA2016	1"1/4"	1"	53,0	20,0	50
	BSPMFFA2020	1"1/4"	1"1/4"	57,0	20,0	50
160	BSPMFFA2412	1"1/2"	3/4"	53,0	20,0	55
	BSPMFFA2416	1"1/2"	1"	53,0	20,0	55
	BSPMFFA2420	1"1/2"	1"1/4"	55,5	20,0	55
	BSPMFFA2424	1"1/2"	1"1/2"	55,5	20,0	55
125	BSPMFFA2432	1"1/2"	2"	58,0	20,0	70
	BSPMFFA3216	2"	1"	52,0	24,5	70
	BSPMFFA3220	2"	1"1/4"	62,0	24,5	70
	BSPMFFA3224	2"	1"1/2"	62,0	24,5	70
	BSPMFFA3232	2"	2"	66,5	24,5	70

PROLUNGA DIRITTA MASCHIO/FEMMINA - SERIE LUNGA

Filetto Gas Cilindrico

MALE/FEMALE CONNECTOR (LONG TYPE)

Thread BSP Parallel

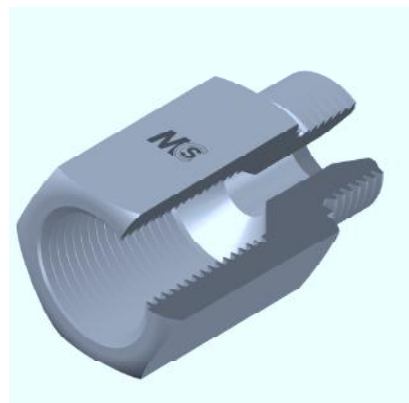
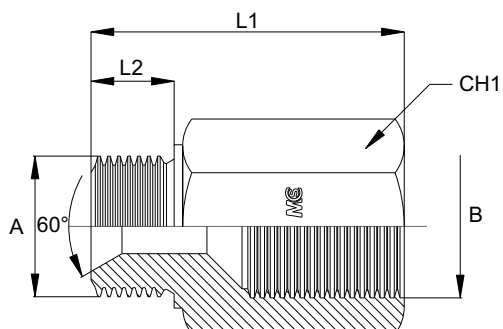

Bar W.P.	Codice Part Number	A	B	L1	L2	CH1
400	BSPMFFA0202L	1/8"	1/8"	-	8,0	14
	BSPMFFA0204L	1/8"	1/4"	49,0	8,0	19
	BSPMFFA0206L	1/8"	3/8"	51,0	8,0	22
	BSPMFFA0402L	1/4"	1/8"	-	11,0	19
	BSPMFFA0404L	1/4"	1/4"	52,0	11,0	19
	BSPMFFA0406L	1/4"	3/8"	52,0	11,0	22
350	BSPMFFA0408L	1/4"	1/2"	56,0	11,0	27
250	BSPMFFA0416L	1/4"	1"	63,5	11,0	38
400	BSPMFFA0604L	3/8"	1/4"	55,0	12,0	22
	BSPMFFA0606L	3/8"	3/8"	55,0	12,0	22
350	BSPMFFA0608L	3/8"	1/2"	57,0	12,0	27
250	BSPMFFA0616L	3/8"	1"	64,5	12,0	38
350	BSPMFFA0804L	1/2"	1/4"	59,0	14,0	27
	BSPMFFA0806L	1/2"	3/8"	58,0	14,0	27
	BSPMFFA0808L	1/2"	1/2"	59,0	14,0	27
315	BSPMFFA0812L	1/2"	3/4"	62,5	14,0	32
	BSPMFFA1204L	3/4"	1/4"	57,5	16,0	32
	BSPMFFA1206L	3/4"	3/8"	59,5	16,0	32
	BSPMFFA1208L	3/4"	1/2"	61,0	16,0	32
	BSPMFFA1212L	3/4"	3/4"	65,0	16,0	32
250	BSPMFFA1216L	3/4"	1"	69,0	16,0	38
125	BSPMFFA1232L	3/4"	2"	74,0	16,0	70
250	BSPMFFA1606L	1"	3/8"	70,5	19,0	41
	BSPMFFA1608L	1"	1/2"	72,5	19,0	41
	BSPMFFA1612L	1"	3/4"	72,5	19,0	41
	BSPMFFA1616L	1"	1"	73,0	19,0	41
200	BSPMFFA1620L	1"	1" 1/4	76,5	20,0	50
160	BSPMFFA1624L	1"	1" 1/2	74,0	20,0	55
200	BSPMFFA2012L	1" 1/4	3/4"	73,0	20,0	50
	BSPMFFA2016L	1" 1/4	1"	73,0	20,0	50
	BSPMFFA2020L	1" 1/4	1" 1/4	77,0	20,0	50
160	BSPMFFA2412L	1" 1/2	3/4"	73,0	20,0	55
	BSPMFFA2416L	1" 1/2	1"	73,0	20,0	55
	BSPMFFA2420L	1" 1/2	1" 1/4	75,5	20,0	55
	BSPMFFA2424L	1" 1/2	1" 1/2	75,5	20,0	55
125	BSPMFFA2432L	1" 1/2	2"	78,0	20,0	70
	BSPMFFA3216L	2"	1"	72,0	24,5	70
	BSPMFFA3220L	2"	1" 1/4	82,0	24,5	70
	BSPMFFA3224L	2"	1" 1/2	82,0	24,5	70
	BSPMFFA3232L	2"	2"	86,5	24,5	70

TAPPO DI RIDUZIONE MASCHIO/FEMMINA

Filetto Gas Cilindrico

MALE/FEMALE REDUCING PLUG

Thread BSP Parallel

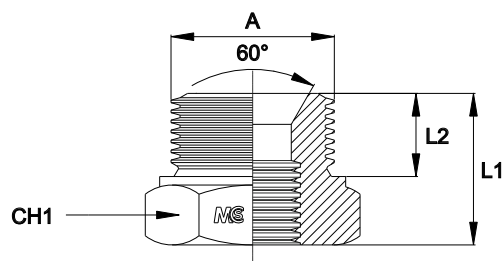

Bar W.P.	Codice Part Number	A	B	L1	L2	CH1
400	BSPMFRP0402	1/4"	1/8"	20,0	11,0	19
	BSPMFRP0602	3/8"	1/8"	22,0	12,0	22
	BSPMFRP0604	3/8"	1/4"	22,0	12,0	22
350	BSPMFRP0802	1/2"	1/8"	24,5	14,0	27
	BSPMFRP0804	1/2"	1/4"	26,5	14,0	27
	BSPMFRP0806	1/2"	3/8"	26,5	14,0	27
	BSPMFRP1008	5/8"	1/2"	31,0	16,0	30
315	BSPMFRP1204	3/4"	1/4"	28,0	16,0	32
	BSPMFRP1206	3/4"	3/8"	28,0	16,0	32
	BSPMFRP1208	3/4"	1/2"	28,0	16,0	32
	BSPMFRP1210	3/4"	5/8"	31,0	16,0	32
250	BSPMFRP1604	1"	1/4"	31,0	19,0	41
	BSPMFRP1606	1"	3/8"	31,0	19,0	41
	BSPMFRP1608	1"	1/2"	31,0	19,0	41
	BSPMFRP1612	1"	3/4"	31,0	19,0	41
200	BSPMFRP2008	1"1/4	1/2"	33,0	20,0	50
	BSPMFRP2012	1"1/4	3/4"	33,0	20,0	50
	BSPMFRP2016	1"1/4	1"	33,0	20,0	50
160	BSPMFRP2416	1"1/2	1"	33,5	20,0	55
	BSPMFRP2420	1"1/2	1"1/4	33,5	20,0	55
125	BSPMFRP3216	2"	1"	41,0	24,5	70
	BSPMFRP3220	2"	1"1/4	41,0	24,5	70
	BSPMFRP3224	2"	1"1/2	41,0	24,5	70

PROLUNGA DIRITTA MASCHIO/FEMMINA

Filetto Metrico Cilindrico

MALE/FEMALE CONNECTOR

Thread Metric Parallel

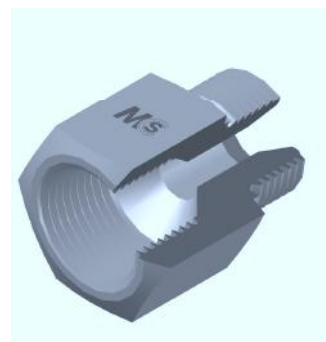
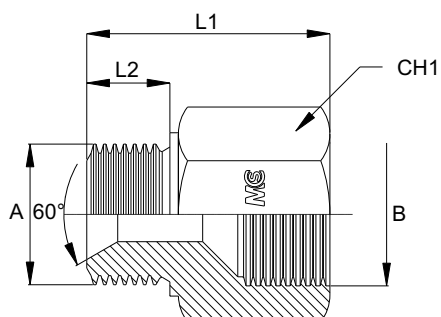

Bar W.P.	Codice Part Number	A	B	L1	L2	CH1
400	MMFFA1010	10x1,0	10x1,0	28,0	8,0	14
	MMFFA1212	12x1,5	12x1,5	30,0	11,0	17
	MMFFA1414	14x1,5	14x1,5	33,0	11,0	19
	MMFFA1616	16x1,5	16x1,5	35,0	12,0	22
	MMFFA1818	18x1,5	18x1,5	35,0	14,0	24
350	MMFFA2020	20x1,5	20x1,5	37,0	14,0	27
	MMFFA2222	22x1,5	22x1,5	40,0	14,0	27
315	MMFFA2626	26x1,5	26x1,5	45,0	16,0	32
250	MMFFA3030	30x1,5	30x1,5	55,0	16,0	36

PROLUNGA DIRITTA MASCHIO/FEMMINA - SERIE LUNGA

Filetto Metrico Cilindrico

MALE/FEMALE CONNECTOR (LONG TYPE)

Thread Metric Parallel

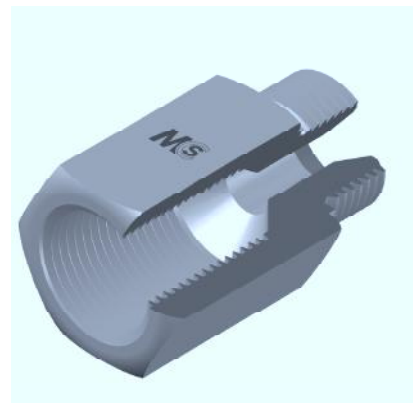
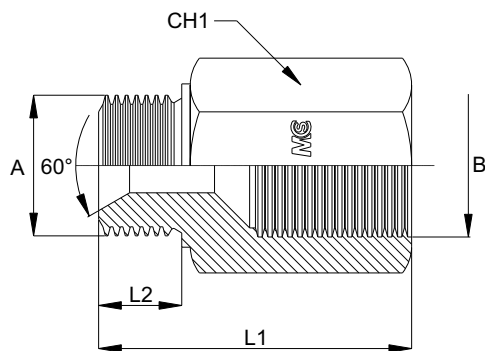

Bar W.P.	Codice Part Number	A	B	L1	L2	CH1
400	MMFFA1010L	10x1,0	10x1,0	38,0	8,0	14
	MMFFA1212L	12x1,5	12x1,5	40,0	11,0	17
	MMFFA1414L	14x1,5	14x1,5	43,0	11,0	19
	MMFFA1616L	16x1,5	16x1,5	45,0	12,0	22
	MMFFA1818L	18x1,5	18x1,5	50,0	14,0	24
350	MMFFA2020L	20x1,5	20x1,5	50,0	14,0	27
	MMFFA2222L	22x1,5	22x1,5	50,0	14,0	27
315	MMFFA2626L	26x1,5	26x1,5	60,0	16,0	32
250	MMFFA3030L	30x1,5	30x1,5	85,0	16,0	36

PROLUNGA DIRITTA MASCHIO/FEMMINA

Filetto NPT

MALE/FEMALE CONNECTOR

Thread NPT

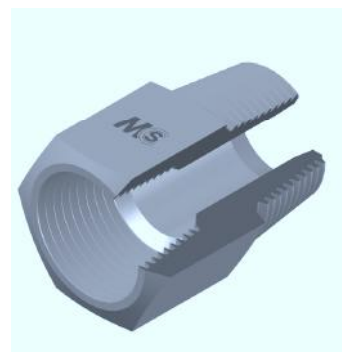
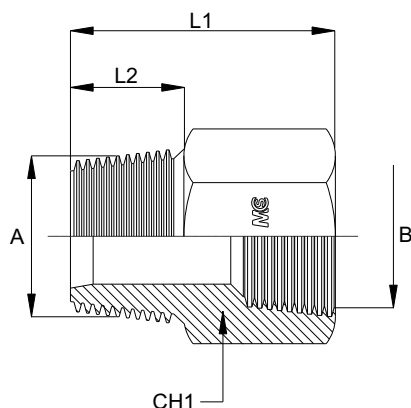

Bar W.P.	Codice Part Number	A	B	L1	L2	CH1
350	NPTMFFA0202	1/8"	1/8"	27,0	10,0	14
	NPTMFFA0204	1/8"	1/4"	27,0	10,0	19
	NPTMFFA0402	1/4"	1/8"	30,0	14,0	14
	NPTMFFA0404	1/4"	1/4"	32,0	14,0	19
250	NPTMFFA0406	1/4"	3/8"	32,0	14,0	22
225	NPTMFFA0408	1/4"	1/2"	37,0	14,0	27
250	NPTMFFA0604	3/8"	1/4"	32,0	14,0	19
	NPTMFFA0606	3/8"	3/8"	32,0	14,0	22
225	NPTMFFA0608	3/8"	1/2"	37,0	14,0	27
	NPTMFFA0804	1/2"	1/4"	35,0	19,0	22
	NPTMFFA0806	1/2"	3/8"	37,0	19,0	22
	NPTMFFA0808	1/2"	1/2"	42,0	19,0	27
200	NPTMFFA0812	1/2"	3/4"	48,0	19,0	32
	NPTMFFA1208	3/4"	1/2"	48,0	19,0	27
	NPTMFFA1212	3/4"	3/4"	48,0	19,0	32
160	NPTMFFA1216	3/4"	1"	48,0	19,0	38
	NPTMFFA1612	1"	3/4"	48,0	24,0	36
	NPTMFFA1616	1"	1"	57,0	24,0	38
	NPTMFFA1620	1"	1"1/4"	57,0	24,0	50
	NPTMFFA2016	1"1/4"	1"	59,0	24,5	46
	NPTMFFA2020	1"1/4"	1"1/4"	59,0	24,5	50
	NPTMFFA2024	1"1/4"	1"1/2"	59,0	24,5	60
	NPTMFFA2424	1"1/2"	1"1/2"	59,0	25,0	60

ADATTATORE MASCHIO/FEMMINA GIREVOLE

Filetto Gas Cilindrico

MALE/SWIVEL FEMALE CONNECTOR

Thread BSP Parallel

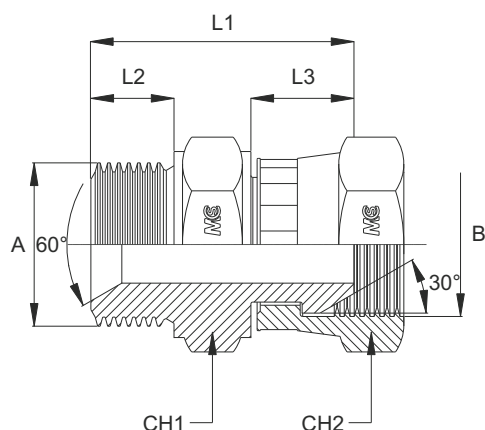

Bar W.P.	Codice Part Number	A	B Tubo Tube O.D.	L1	L2	L3	CH1	CH2
350	BSPMSFA0202	1/8"	1/8"	27,7	8,0	9,7	14	17
	BSPMSFA0404	1/4"	1/4"	32,5	11,0	9,7	19	19
250	BSPMSFA0606	3/8"	3/8"	35,5	12,0	12,3	22	22
225	BSPMSFA0808	1/2"	1/2"	40,0	14,0	14,5	27	27
200	BSPMSFA1212	3/4"	3/4"	45,0	16,0	16,0	32	32
160	BSPMSFA1616	1"	1"	52,0	19,0	16,8	41	38
	BSPMSFA2020	1" 1/4	1" 1/4	53,0	20,0	16,5	50	50
	BSPMSFA2424	1" 1/2	1" 1/2	58,0	20,0	20,5	55	55

Reducing Adaptor - Riduzioni

350	BSPMSFA0204	1/8"	1/4"	30,0	8,0	10,0	14	19
	BSPMSFA0406	1/4"	3/8"	35,0	11,0	12,5	19	22
250	BSPMSFA0604	3/8"	1/4"	35,0	12,0	10,0	22	19
	BSPMSFA0608	3/8"	1/2"	38,0	12,0	14,5	22	27
225	BSPMSFA0812	1/2"	3/4"	42,0	14,0	16,0	27	32
	BSPMSFA0816	1/2"	1"	46,5	14,0	17,0	27	38
200	BSPMSFA1208	3/4"	1/2"	43,5	16,0	14,5	32	27
	BSPMSFA1216	3/4"	1"	49,0	16,0	17,0	32	38
160	BSPMSFA1620	1"	1" 1/4	49,5	17,0	16,5	41	50
	BSPMSFA1624	1"	1" 1/2	55,0	17,0	20,5	46	55
160	BSPMSFA2024	1" 1/4	1" 1/2	58,0	20,0	20,5	50	55

ADATTATORE MASCHIO/FEMMINA GIREVOLE CON GUARNIZIONE

Filetto Gas Cilindrico

MALE/SWIVEL FEMALE CONNECTOR WITH CAPTIVE SEAL

Thread BSP Parallel

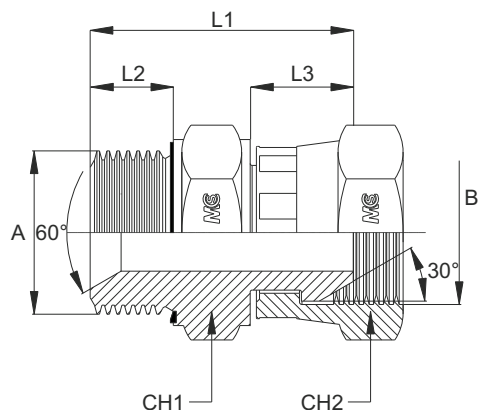

Bar W.P.	Codice Part Number	A	B	L1	L2	L3	CH1	CH2
400	BSPMSFA0202V	1/8"	1/8"	27,7	8,0	9,7	14	17
	BSPMSFA0404V	1/4"	1/4"	32,5	11,0	9,7	19	19
	BSPMSFA0606V	3/8"	3/8"	35,5	12,0	12,3	22	22
350	BSPMSFA0808V	1/2"	1/2"	40,0	14,0	14,5	27	27
	BSPMSFA1010V	5/8"	5/8"	-	16,0	-	30	30
315	BSPMSFA1212V	3/4"	3/4"	45,0	16,0	16,0	32	32
250	BSPMSFA1616V	1"	1"	52,0	19,0	16,8	41	38
200	BSPMSFA2020V	1" 1/4	1" 1/4	53,0	20,0	16,5	50	50
160	BSPMSFA2424V	1" 1/2	1" 1/2	58,0	20,0	20,5	55	55
125	BSPMSFA3232V	2"	2"	-	24,5	-	70	70

NOTE: VITON® è un marchio registrato dalla DuPont Dow Elastomers
 NOTE: VITON® is a DuPont Dow Elastomers Trade Mark

ADATTATORE MASCHIO/FEMMINA GIREVOLE

Filetto Maschio NPT/Femmina NPSM

MALE/SWIVEL FEMALE CONNECTOR

Male Thread NPT/Female Thread NPSM

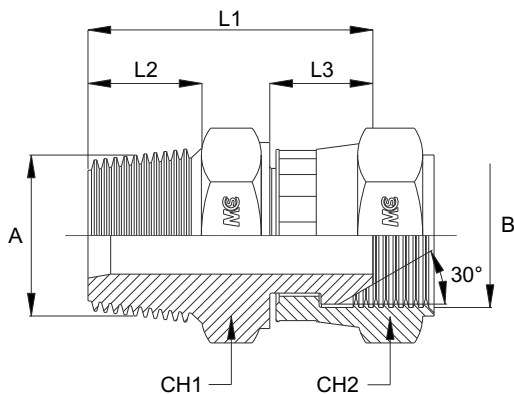

Bar W.P.	Codice Part Number	A	B	L1	L2	L3	CH1	CH2
350	NPTMSFA0202	1/8"	1/8"	28,5	10,0	10,0	14	17
	NPTMSFA0404	1/4"	1/4"	34,5	14,0	10,0	14	19
250	NPTMSFA0606	3/8"	3/8"	37,0	14,0	12,5	19	22
225	NPTMSFA0808	1/2"	1/2"	46,0	19,0	14,5	22	27
200	NPTMSFA1212	3/4"	3/4"	46,0	19,0	16,0	27	32
160	NPTMSFA1616	1"	1"	55,0	24,0	17,0	36	38
	NPTMSFA2020	1" 1/4	1" 1/4	55,5	25,0	16,5	46	50
	NPTMSFA2424	1" 1/2	1" 1/2	61,0	25,0	20,5	50	55

ADATTATORE MASCHIO/FEMMINA GIREVOLE

Filetto Maschio Gas Conico/Femmina Gas Cilindrico

MALE/SWIVEL FEMALE CONNECTOR

Male Thread BSP Taper/Female Thread BSP Parallel

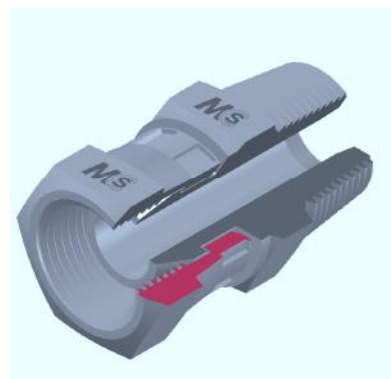
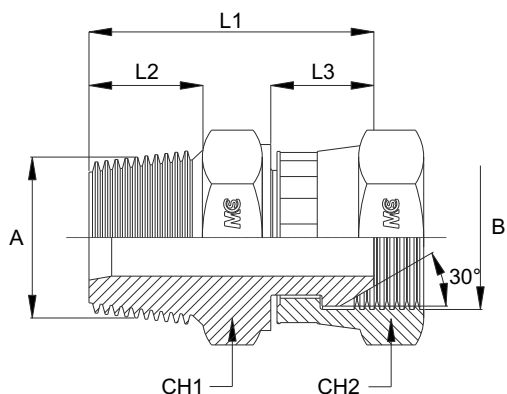

Bar W.P.	Codice Part Number	A	B	L1	L2	L3	CH1	CH2
350	BSPTBSPMSFA0202	1/8"	1/8"	26,5	8,0	10,0	14	17
300	BSPTBSPMSFA0404	1/4"	1/4"	33,5	13,0	10,0	14	19
280	BSPTBSPMSFA0606	3/8"	3/8"	37,0	14,0	12,5	19	22
200	BSPTBSPMSFA0808	1/2"	1/2"	44,0	17,0	14,5	22	27
	BSPTBSPMSFA1212	3/4"	3/4"	44,5	17,5	16,0	27	32
120	BSPTBSPMSFA1616	1"	1"	53,0	22,0	17,0	36	38
105	BSPTBSPMSFA2020	1" 1/4	1" 1/4	54,5	24,0	16,5	46	50
	BSPTBSPMSFA2424	1" 1/2	1" 1/2	60,0	24,0	20,5	50	55

ADATTATORE MASCHIO/FEMMINA GIREVOLE

Filetto Maschio NPT/Femmina Gas Cilindrico

MALE/SWIVEL FEMALE CONNECTOR

Male Thread NPT/Female Thread BSP Parallel

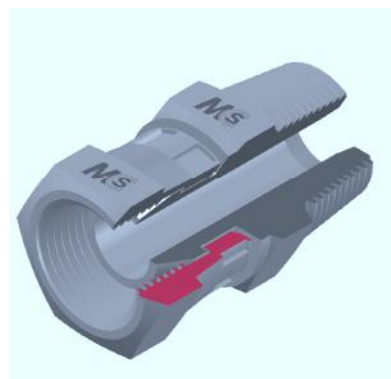
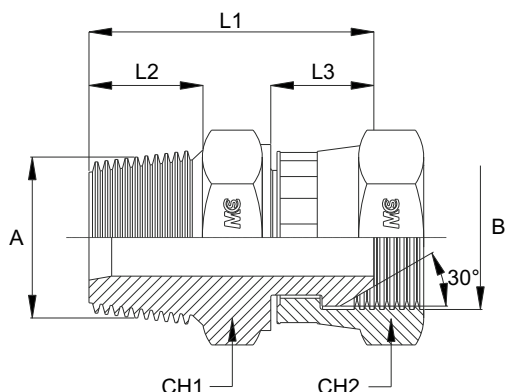

Bar W.P.	Codice Part Number	A	B	L1	L2	L3	CH1	CH2
350	NPTBSPMSFA0202	1/8"	1/8"	28,5	10,0	10,0	14	17
	NPTBSPMSFA0404	1/4"	1/4"	34,5	14,0	10,0	14	19
250	NPTBSPMSFA0606	3/8"	3/8"	37,0	14,0	12,5	19	22
225	NPTBSPMSFA0808	1/2"	1/2"	46,0	19,0	14,5	22	27
200	NPTBSPMSFA1212	3/4"	3/4"	46,0	19,0	16,0	27	32
	NPTBSPMSFA1616	1"	1"	55,0	24,0	17,0	36	38
	NPTBSPMSFA2020	1" 1/4	1" 1/4	55,5	25,0	16,5	46	50
	NPTBSPMSFA2424	1" 1/2	1" 1/2	61,0	25,0	20,5	50	55

ADATTATORE A 90° MASCHIO INTERMEDIO

Filetto Gas Cilindrico

MALE EQUAL ELBOW

Thread BSP Parallel

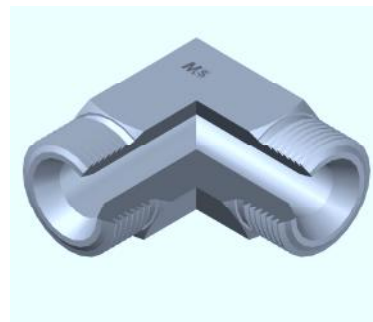
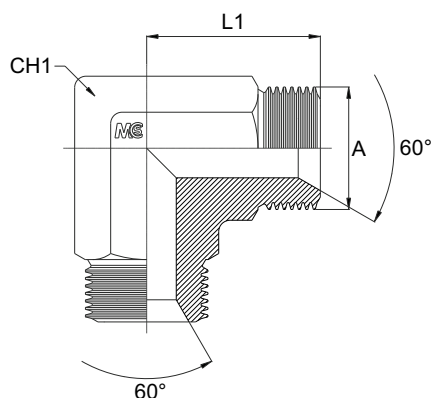

Bar W.P.	Codice Part Number	A	L1	CH1
400	LBSPMA0202	1/8"	21,0	12
	LBSPMA0404	1/4"	26,0	14
	LBSPMA0606	3/8"	29,0	19
350	LBSPMA0808	1/2"	34,0	22
	LBSPMA1010	5/8"	38,0	27
315	LBSPMA1212	3/4"	41,0	27
250	LBSPMA1616	1"	45,0	33
220	LBSPMA2020	1" 1/4	52,0	41
170	LBSPMA2424	1" 1/2	59,0	50
125	LBSPMA3232	2"	78,0	65

ADATTATORE A 90° MASCHIO INTERMEDIO

Filetto Metrico Cilindrico

MALE EQUAL ELBOW

Thread Metric Parallel

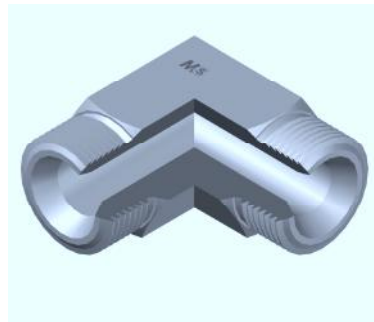
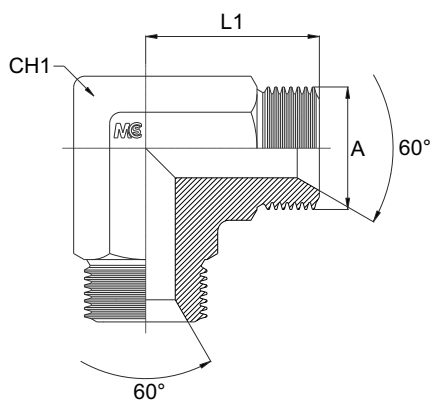

Bar W.P.	Codice Part Number	A	L1	CH1
400	LMMA1010	10x1,0	21,0	12
	LMMA1212	12x1,5	21,0	12
	LMMA1414	14x1,5	26,0	14
	LMMA1616	16x1,5	29,0	19
	LMMA1818	18x1,5	29,0	19
350	LMMA2020	20x1,5	34,0	22
	LMMA2222	22x1,5	34,0	22
315	LMMA2626	26x1,5	41,0	27
250	LMMA3030	30x1,5	45,0	33

ADATTATORE A 90° MASCHIO INTERMEDIO

Filetto Gas Conico

MALE EQUAL ELBOW

Thread BSP Taper

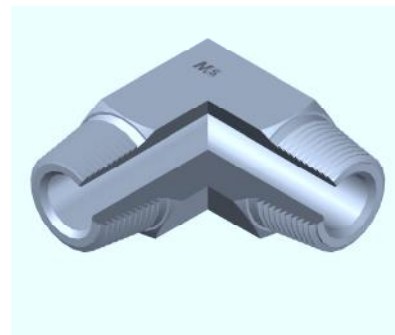
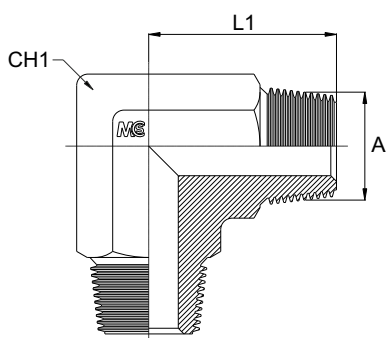

Bar W.P.	Codice Part Number	A	L1	CH1
350	LBSPTMA0202	1/8"	20,0	12
	LBSPTMA0404	1/4"	28,0	14
250	LBSPTMA0606	3/8"	31,0	19
225	LBSPTMA0808	1/2"	37,5	22
200	LBSPTMA1212	3/4"	40,0	27
160	LBSPTMA1616	1"	50,0	33
	LBSPTMA2020	1" 1/4	60,0	41
	LBSPTMA2424	1" 1/2	67,0	50
100	LBSPTMA3232	2"	76,0	65

ADATTATORE A «T» INTERMEDIO MASCHIO

Filetto Gas Conico

MALE EQUAL TEE

Thread BSP Taper

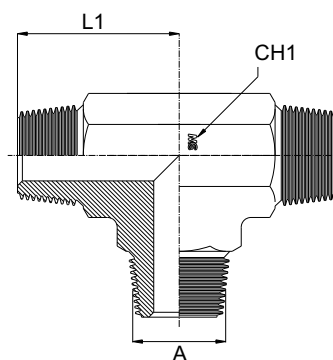

Bar W.P.	Codice Part Number	A	L1	CH1
350	TBSPTMA0202	1/8"	20,0	12
	TBSPTMA0404	1/4"	28,0	14
250	TBSPTMA0606	3/8"	31,0	19
225	TBSPTMA0808	1/2"	37,5	22
200	TBSPTMA1212	3/4"	40,0	27
160	TBSPTMA1616	1"	50,0	33
	TBSPTMA2020	1" 1/4	60,0	41
	TBSPTMA2424	1" 1/2	67,0	50
100	TBSPTMA3232	2"	76,0	65

ADATTATORE A 90° MASCHIO INTERMEDIO

Filetto NPT

MALE EQUAL ELBOW

Thread NPT

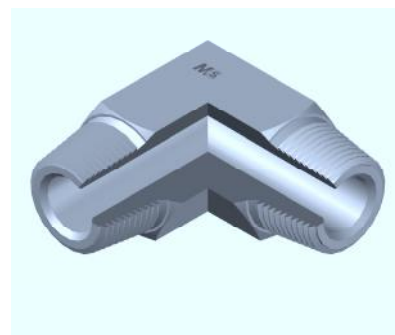
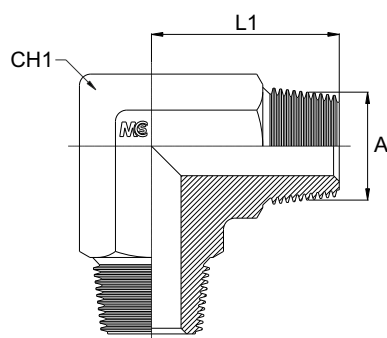

Bar W.P.	Codice Part Number	A	L1	CH1
350	LNPTMA0202	1/8"	20,0	12
	LNPTMA0404	1/4"	28,0	14
250	LNPTMA0606	3/8"	31,0	19
225	LNPTMA0808	1/2"	37,5	22
200	LNPTMA1212	3/4"	40,0	27
160	LNPTMA1616	1"	50,0	33
	LNPTMA2020	1" 1/4	60,0	41
	LNPTMA2424	1" 1/2	67,0	50
100	LNPTMA3232	2"	76,0	65

ADATTATORE A «T» INTERMEDIO MASCHIO

Filetto NPT

MALE EQUAL TEE

Thread NPT

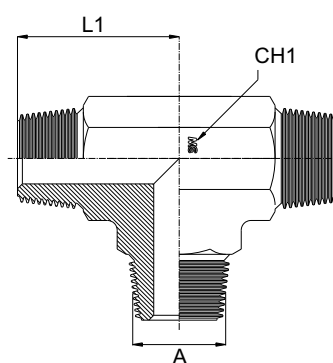

Bar W.P.	Codice Part Number	A	L1	CH1
350	TNPTMA0202	1/8"	20,0	12
	TNPTMA0404	1/4"	28,0	14
250	TNPTMA0606	3/8"	31,0	19
225	TNPTMA0808	1/2"	37,5	22
200	TNPTMA1212	3/4"	40,0	27
160	TNPTMA1616	1"	50,0	33
	TNPTMA2020	1" 1/4	60,0	41
	TNPTMA2424	1" 1/2	67,0	50
100	TNPTMA3232	2"	76,0	65

ADATTATORE A 90° MASCHIO DI ESTREMITÀ

Filetto Gas Cilindrico/Conico

MALE STUD ELBOW

Thread BSP Parallel/BSP Taper

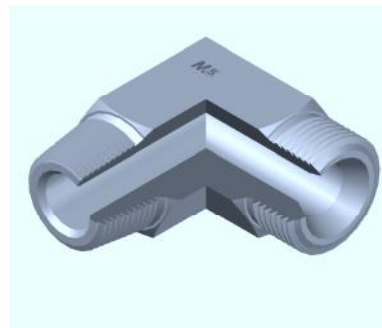
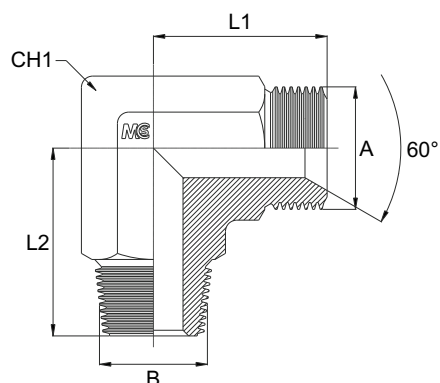

Bar W.P.	Codice Part Number	A	B	L1	L2	CH1
350	LBSPBSPTMA0202	1/8"	1/8"	21,0	20,0	12
	LBSPBSPTMA0404	1/4"	1/4"	26,0	28,0	14
250	LBSPBSPTMA0606	3/8"	3/8"	29,0	31,0	19
225	LBSPBSPTMA0808	1/2"	1/2"	34,0	37,5	22
200	LBSPBSPTMA1010	5/8"	5/8"	38,0	40,0	27
	LBSPBSPTMA1212	3/4"	3/4"	41,0	40,0	27
160	LBSPBSPTMA1616	1"	1"	45,0	50,0	33
	LBSPBSPTMA2020	1" 1/4	1" 1/4	52,0	60,0	41
	LBSPBSPTMA2424	1" 1/2	1" 1/2	59,0	67,0	50
100	LBSPBSPTMA3232	2"	2"	78,0	76,0	65

ADATTATORE A 90° MASCHIO DI ESTREMITÀ

Filetto Gas Cilindrico/NPT

MALE STUD ELBOW

Thread BSP Parallel/NPT

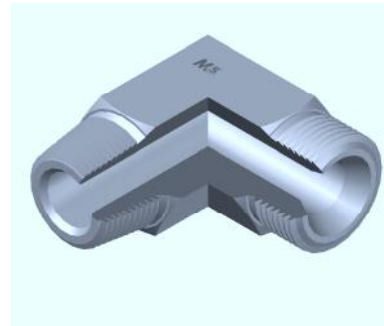
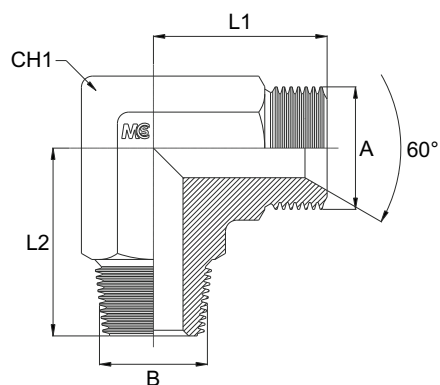

Bar W.P.	Codice Part Number	A	B	L1	L2	CH1
350	LBSPNPTMA0202	1/8"	1/8"	21,0	20,0	12
	LBSPNPTMA0404	1/4"	1/4"	26,0	28,0	14
250	LBSPNPTMA0606	3/8"	3/8"	29,0	31,0	19
225	LBSPNPTMA0808	1/2"	1/2"	34,0	37,5	22
200	LBSPNPTMA1010	5/8"	5/8"	38,0	40,0	27
	LBSPNPTMA1212	3/4"	3/4"	41,0	40,0	27
160	LBSPNPTMA1616	1"	1"	45,0	50,0	33
	LBSPNPTMA2020	1" 1/4	1" 1/4	52,0	60,0	41
	LBSPNPTMA2424	1" 1/2	1" 1/2	59,0	67,0	50
100	LBSPNPTMA3232	2"	2"	78,0	76,0	65

ADATTATORE A 90° FEMMINA INTERMEDIO

Filetto Gas Cilindrico

FEMALE EQUAL ELBOW

Thread BSP Parallel

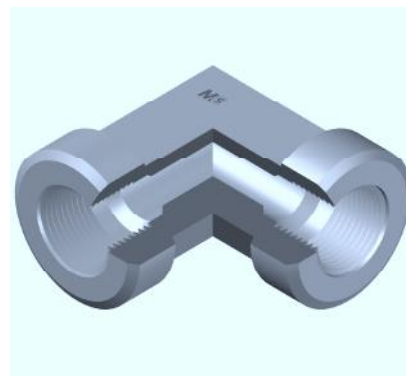
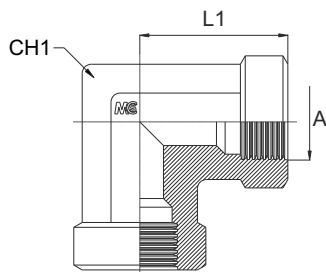

Bar W.P.	Codice Part Number	A	L1	CH1
350	LBSPFFA0202	1/8"	17,0	14
	LBSPFFA0404	1/4"	22,5	19
250	LBSPFFA0606	3/8"	26,0	22
225	LBSPFFA0808	1/2"	31,0	27
200	LBSPFFA1212	3/4"	34,5	33
160	LBSPFFA1616	1"	41,0	41
	LBSPFFA2020	1" 1/4	43,0	50
	LBSPFFA2424	1" 1/2	53,0	65
100	LBSPFFA3232	2"	61,0	70

ADATTATORE A 90° FEMMINA INTERMEDIO

Filetto NPT

FEMALE EQUAL ELBOW

Thread NPT

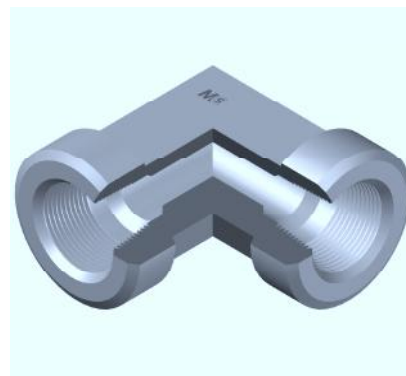
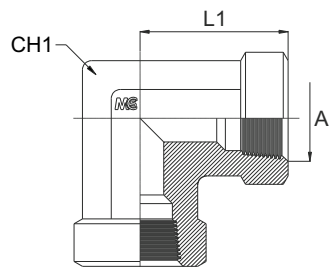

Bar W.P.	Codice Part Number	A	L1	CH1
350	LNPTFFA0202	1/8"	17,0	14
	LNPTFFA0404	1/4"	22,5	19
250	LNPTFFA0606	3/8"	26,0	22
225	LNPTFFA0808	1/2"	31,0	27
200	LNPTFFA1212	3/4"	34,5	33
160	LNPTFFA1616	1"	41,0	41
	LNPTFFA2020	1" 1/4	43,0	50
	LNPTFFA2424	1" 1/2	53,0	65
100	LNPTFFA3232	2"	61,0	70

ADATTATORE A 90° FEMMINA GIREVOLE

Filetto Gas Cilindrico

SWIVEL FEMALE EQUAL ELBOW

Thread BSP Parallel

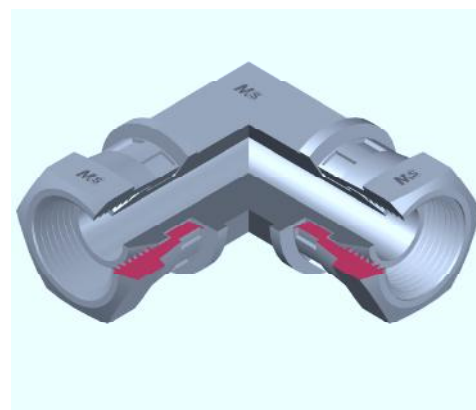
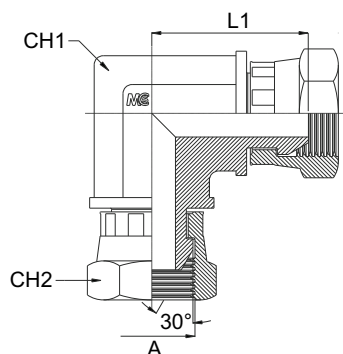

Bar W.P.	Codice Part Number	A	L1	CH1	CH2
400	LBSPSFA0202	1/8"	18,0	12	17
	LBSPSFA0404	1/4"	23,5	14	19
	LBSPSFA0606	3/8"	25,5	19	22
350	LBSPSFA0808	1/2"	29,5	22	27
	LBSPSFA1010	5/8"	-	27	30
315	LBSPSFA1212	3/4"	37,0	27	32
250	LBSPSFA1616	1"	43,0	33	38
200	LBSPSFA2020	1" 1/4	51,0	41	50
160	LBSPSFA2424	1" 1/2	59,0	50	55
125	LBSPSFA3232	2"	-	65	70

ADATTATORE A 90° FEMMINA GIREVOLE

Filetto Metrico Cilindrico

SWIVEL FEMALE EQUAL ELBOW

Thread Metric Parallel

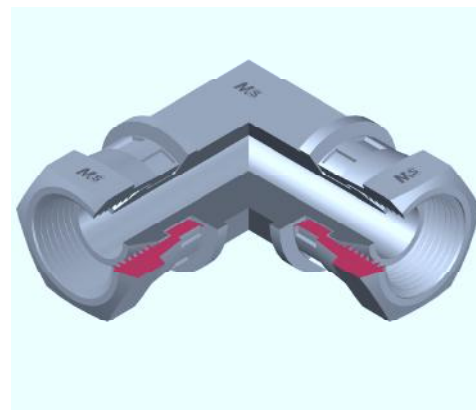
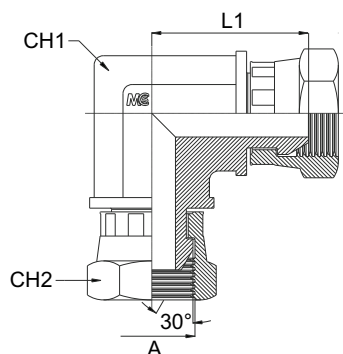

Bar W.P.	Codice Part Number	A	L1	CH1	CH2
400	LMSFA1212	12x1,5	18,0	12	17
	LMSFA1414	14x1,5	23,5	14	19
	LMSFA1616	16x1,5	25,5	19	22
	LMSFA1818	18x1,5	29,5	19	24
350	LMSFA2020	20x1,5	37,0	22	27
	LMSFA2222	22x1,5	43,0	22	27
315	LMSFA2626	26x1,5	51,0	27	32
250	LMSFA3030	30x1,5	59,0	33	36

ADATTATORE A 90° FEMMINA/FEMMINA GIREVOLE

Filetto Gas Cilindrico

90° SWIVEL ELBOW FEMALE/FEMALE

Thread BSP Parallel

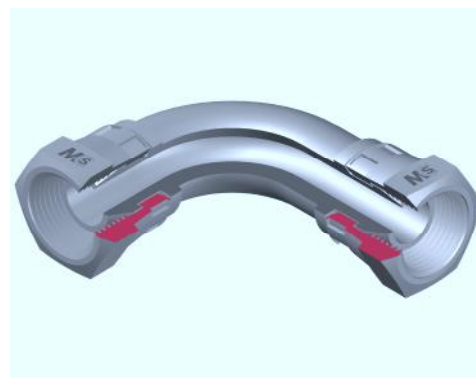
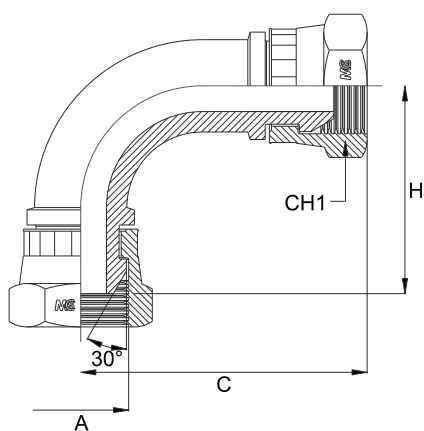

Bar W.P.	Codice Part Number	A	B	C	H	CH1
400	90BSPSFA0202	1/8"	1/8"	-	-	17
	90BSPSFA0404	1/4"	1/4"	29,0	27,0	19
	90BSPSFA0606	3/8"	3/8"	39,0	37,0	22
350	90BSPSFA0808	1/2"	1/2"	46,0	45,0	27
315	90BSPSFA1212	3/4"	3/4"	63,0	61,0	32
250	90BSPSFA1616*	1"	1"	-	-	38
200	90BSPSFA2020*	1" 1/4	1" 1/4	-	-	50
160	90BSPSFA2424*	1" 1/2	1" 1/2	-	-	55

* Saldato

* Welded

ADATTATORE A 90° MASCHIO/FEMMINA

Filetto Gas Conico/Cilindrico

MALE/FEMALE STUD ELBOW

Thread BSP Taper/BSP Parallel

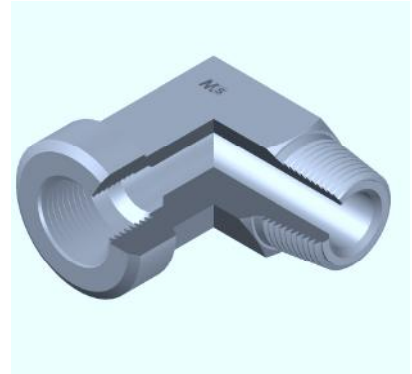
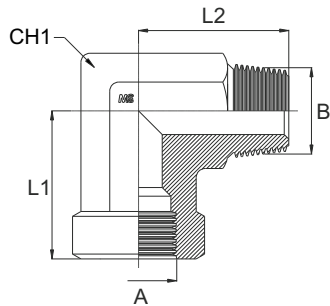

Bar W.P.	Codice Part Number	A	B	L1	L2	CH1
350	LBSPTBSPMFA0202	1/8"	1/8"	17,0	20,0	14
	LBSPTBSPMFA0404	1/4"	1/4"	22,5	28,0	19
250	LBSPTBSPMFA0606	3/8"	3/8"	26,0	31,0	22
225	LBSPTBSPMFA0808	1/2"	1/2"	31,0	37,5	27
200	LBSPTBSPMFA1212	3/4"	3/4"	34,5	40,0	33
	LBSPTBSPMFA1616	1"	1"	41,0	50,0	41
160	LBSPTBSPMFA2020	1" 1/4	1" 1/4	43,0	60,0	50
	LBSPTBSPMFA2424	1" 1/2	1" 1/2	53,0	67,0	65
100	LBSPTBSPMFA3232	2"	2"	61,0	76,0	70

ADATTATORE A 90° MASCHIO/FEMMINA

Filetto NPT/Gas Cilindrico

MALE/FEMALE STUD ELBOW

Thread NPT/BSP Parallel

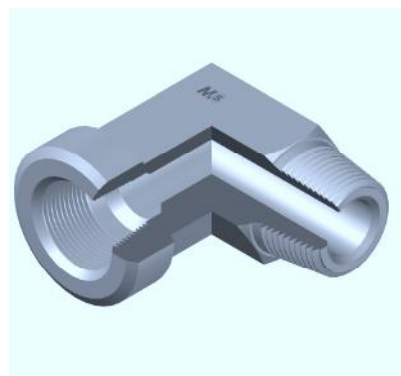
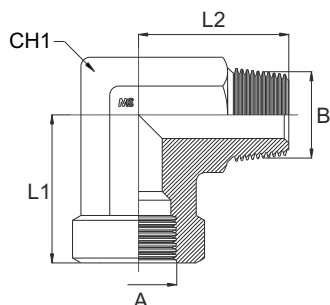

Bar W.P.	Codice Part Number	A	B	L1	L2	CH1
350	LNPTBSPMFA0202	1/8"	1/8"	17,0	20,0	14
	LNPTBSPMFA0404	1/4"	1/4"	22,5	28,0	19
250	LNPTBSPMFA0606	3/8"	3/8"	26,0	31,0	22
225	LNPTBSPMFA0808	1/2"	1/2"	31,0	37,5	27
200	LNPTBSPMFA1212	3/4"	3/4"	34,5	40,0	33
	LNPTBSPMFA1616	1"	1"	41,0	50,0	41
160	LNPTBSPMFA2020	1" 1/4	1" 1/4	43,0	60,0	50
	LNPTBSPMFA2424	1" 1/2	1" 1/2	53,0	67,0	65
100	LNPTBSPMFA3232	2"	2"	61,0	76,0	70

ADATTATORE A 90° MASCHIO/FEMMINA GIREVOLE

Filetto Gas Cilindrico

MALE/SWIVEL FEMALE STUD ELBOW

Thread BSP Parallel

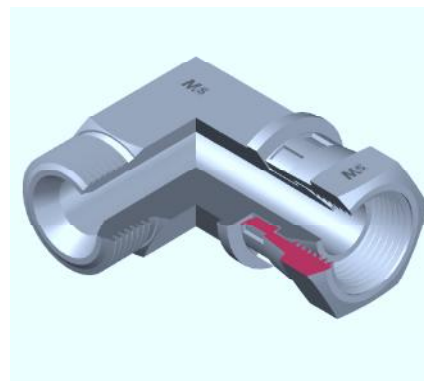
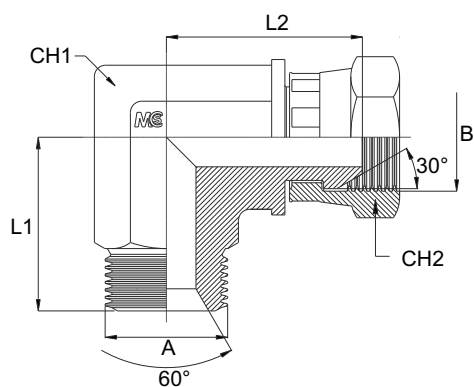

Bar W.P.	Codice Part Number	A	B	L1	L2	CH1	CH2
400	LBSPMSFA0202	1/8"	1/8"	21,0	18,0	12	17
	LBSPMSFA0404	1/4"	1/4"	26,0	23,5	14	19
	LBSPMSFA0606	3/8"	3/8"	29,0	25,5	19	22
350	LBSPMSFA0808	1/2"	1/2"	34,0	29,5	22	27
	LBSPMSFA1010	5/8"	5/8"	38,0	-	27	30
315	LBSPMSFA1212	3/4"	3/4"	41,0	37,0	27	32
250	LBSPMSFA1616	1"	1"	45,0	43,0	33	38
200	LBSPMSFA2020	1" 1/4	1" 1/4	57,0	51,0	41	50
160	LBSPMSFA2424	1" 1/2	1" 1/2	59,0	59,0	50	55
125	LBSPMSFA3232	2"	2"	78,0	-	65	70

ADATTATORE A 90° MASCHIO/FEMMINA GIREVOLE

Filetto Metrico Cilindrico

MALE/SWIVEL FEMALE STUD ELBOW

Thread Metric Parallel

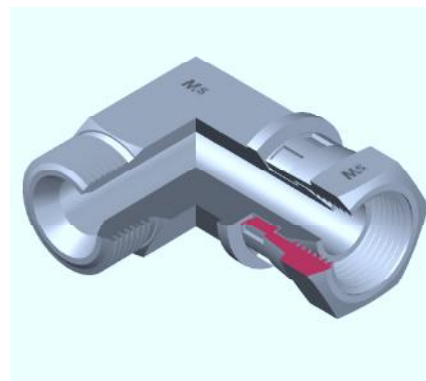
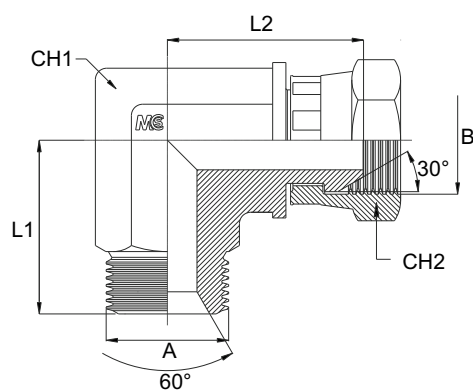

Bar W.P.	Codice Part Number	A	B	L1	L2	CH1	CH2
400	LMMSFA1212	12x1,5	12x1,5	21,0	18,0	12	17
	LMMSFA1414	14x1,5	14x1,5	26,0	23,5	14	19
	LMMSFA1616	16x1,5	16x1,5	29,0	25,5	19	22
	LMMSFA1818	18x1,5	18x1,5	29,0	29,5	19	24
350	LMMSFA2020	20x1,5	20x1,5	34,0	37,0	22	27
	LMMSFA2222	22x1,5	22x1,5	34,0	43,0	22	27
315	LMMSFA2626	26x1,5	26x1,5	41,0	51,0	27	32
250	LMMSFA3030	30x1,5	30x1,5	45,0	59,0	33	36

ADATTATORE A 90° MASCHIO/FEMMINA GIREVOLE

Filetto Maschio Gas Conico/Femmina Gas Cilindrico

MALE/SWIVEL FEMALE STUD ELBOW

Male Thread BSP Taper/Female Thread BSP Parallel

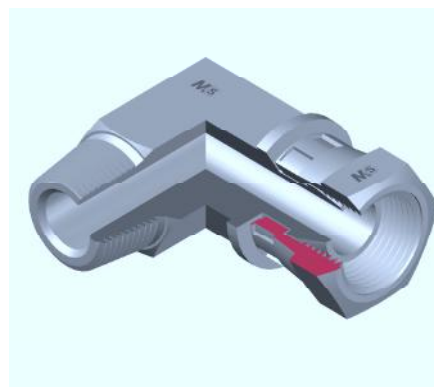
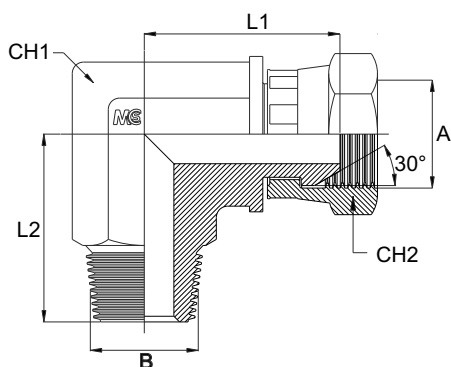

Bar W.P.	Codice Part Number	A	B	L1	L2	CH1	CH2
350	LBSPTBSPMSFA0202	1/8"	1/8"	18,0	20,0	12	17
	LBSPTBSPMSFA0404	1/4"	1/4"	23,5	28,0	14	19
250	LBSPTBSPMSFA0606	3/8"	3/8"	25,5	31,0	19	22
225	LBSPTBSPMSFA0808	1/2"	1/2"	29,5	37,5	22	27
200	LBSPTBSPMSFA1010	5/8"	5/8"	-	37,5	27	30
	LBSPTBSPMSFA1212	3/4"	3/4"	37,0	40,0	27	32
160	LBSPTBSPMSFA1616	1"	1"	43,0	50,0	33	38
	LBSPTBSPMSFA2020	1" 1/4	1" 1/4	51,0	60,0	41	50
	LBSPTBSPMSFA2424	1" 1/2	1" 1/2	59,0	67,0	50	55
100	LBSPTBSPMSFA3232	2"	2"	-	76,0	65	70

ADATTATORE A 90° MASCHIO/FEMMINA GIREVOLE

Filetto Maschio NPT/Femmina Gas Cilindrico

MALE/SWIVEL FEMALE STUD ELBOW

Male Thread NPT/Female Thread BSP Parallel

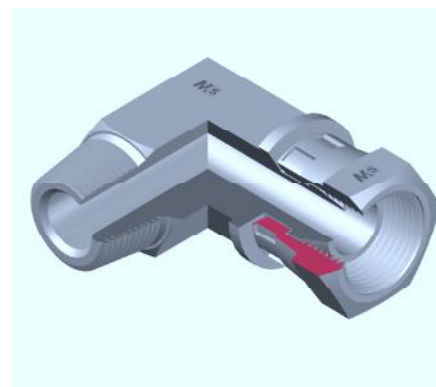
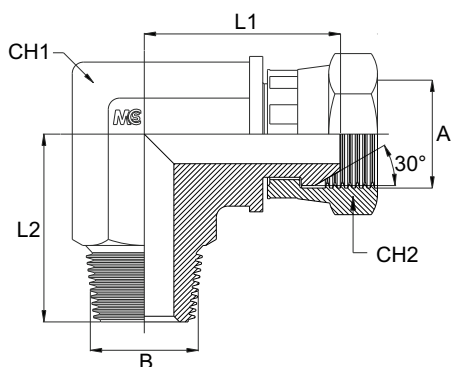

Bar W.P.	Codice Part Number	A	B	L1	L2	CH1	CH2
350	LNPTBSPMSFA0202	1/8"	1/8"	18,0	20,0	12	17
	LNPTBSPMSFA0404	1/4"	1/4"	23,5	28,0	14	19
250	LNPTBSPMSFA0606	3/8"	3/8"	25,5	31,0	19	22
225	LNPTBSPMSFA0808	1/2"	1/2"	29,5	37,5	22	27
200	LNPTBSPMSFA1010	5/8"	5/8"	-	37,5	27	30
	LNPTBSPMSFA1212	3/4"	3/4"	37,0	40,0	27	32
160	LNPTBSPMSFA1616	1"	1"	43,0	50,0	33	38
	LNPTBSPMSFA2020	1" 1/4	1" 1/4	51,0	60,0	41	50
	LNPTBSPMSFA2424	1" 1/2	1" 1/2	59,0	67,0	50	55
100	LNPTBSPMSFA3232	2"	2"	-	76,0	65	70

ADATTATORE A 90° MASCHIO/FEMMINA GIREVOLE

Filetto Gas Cilindrico

90° SWIVEL ELBOW MALE/FEMALE

Thread BSP Parallel

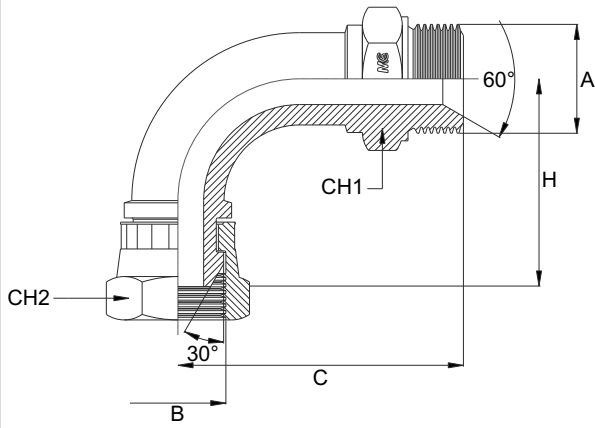

Bar W.P.	Codice Part Number	A	B	C	H	CH1	CH2
400	90BSPMSFA0202	1/8"	1/8"	-	-	17	17
	90BSPMSFA0404	1/4"	1/4"	38,0	27,0	19	19
	90BSPMSFA0606	3/8"	3/8"	46,0	40,0	22	22
350	90BSPMSFA0808	1/2"	1/2"	56,0	48,0	27	27
315	90BSPMSFA1212	3/4"	3/4"	80,0	68,0	32	32
250	90BSPMSFA1616*	1"	1"	102,0	75,0	41	38
200	90BSPMSFA2020*	1" 1/4	1" 1/4	-	-	50	50
160	90BSPMSFA2424*	1" 1/2	1" 1/2	-	-	55	55

* Saldato

* Welded

ADATTATORE A «T» INTERMEDIO MASCHIO

Filetto Gas Cilindrico

MALE EQUAL TEE

Thread BSP Parallel

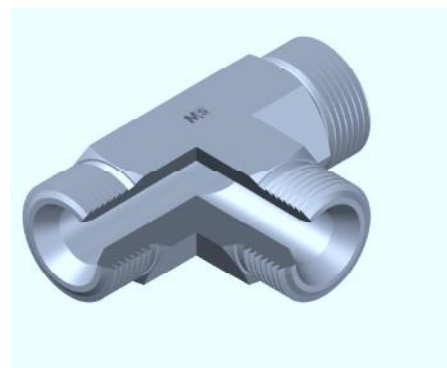
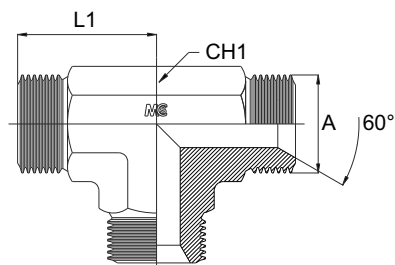

Bar W.P.	Codice Part Number	A	L1	CH1
400	TBSPMA0202	1/8"	21,0	12
	TBSPMA0404	1/4"	26,0	14
	TBSPMA0606	3/8"	29,0	19
350	TBSPMA0808	1/2"	34,0	22
	TBSPMA1010	5/8"	38,0	27
315	TBSPMA1212	3/4"	41,0	27
250	TBSPMA1616	1"	45,0	33
220	TBSPMA2020	1" 1/4	52,0	41
170	TBSPMA2424	1" 1/2	59,0	50
125	TBSPMA3232	2"	78,0	65

ADATTATORE A «T» INTERMEDIO MASCHIO

Filetto Metrico Cilindrico

MALE EQUAL TEE

Thread Metric Parallel

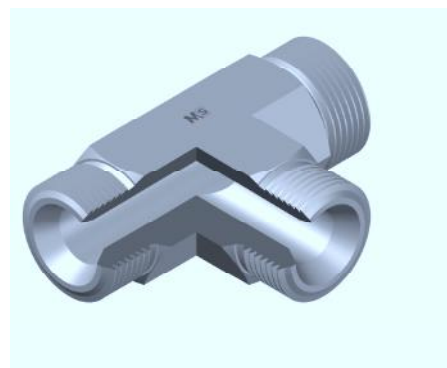
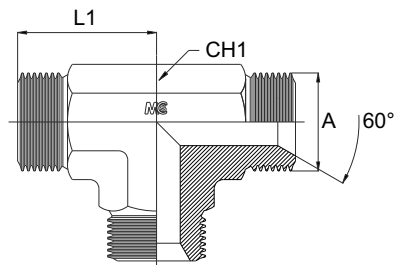

Bar W.P.	Codice Part Number	A	L1	CH1
400	TMMA1010	10x1,0	21,0	12
	TMMA1212	12x1,5	21,0	12
	TMMA1414	14x1,5	26,0	14
	TMMA1616	16x1,5	29,0	19
	TMMA1818	18x1,5	29,0	19
350	TMMA2020	20x1,5	34,0	22
	TMMA2222	22x1,5	34,0	22
315	TMMA2626	26x1,5	41,0	27
250	TMMA3030	30x1,5	45,0	33

ADATTATORE A «T» MASCHIO DI ESTREMITÀ LATERALE

Filetto Gas Cilindrico/Conico

MALE STUD BARREL TEE

Thread BSP Parallel/BSP Taper

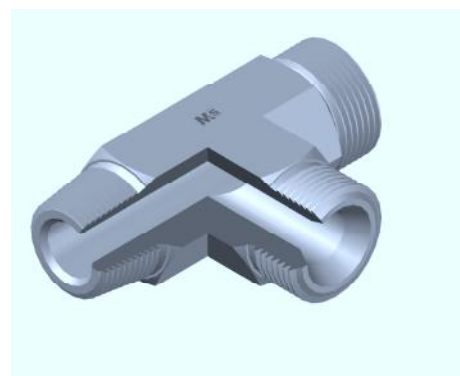
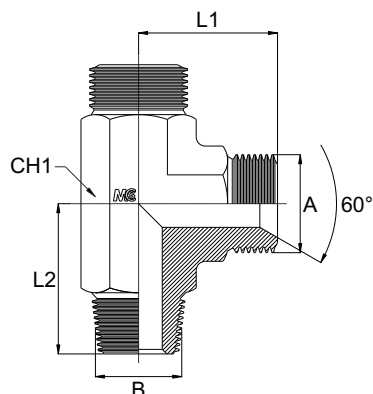

Bar W.P.	Codice Part Number	A	B	L1	L2	CH1
350	TLBSPBSPTMA0202	1/8"	1/8"	21,0	20,0	12
	TLBSPBSPTMA0404	1/4"	1/4"	26,0	28,0	14
250	TLBSPBSPTMA0606	3/8"	3/8"	29,0	31,0	19
225	TLBSPBSPTMA0808	1/2"	1/2"	34,0	37,5	22
200	TLBSPBSPTMA1010	5/8"	5/8"	38,0	40,0	27
	TLBSPBSPTMA1212	3/4"	3/4"	41,0	40,0	27
160	TLBSPBSPTMA1616	1"	1"	45,0	50,0	33
	TLBSPBSPTMA2020	1"1/4	1"1/4	52,0	60,0	41
	TLBSPBSPTMA2424	1"1/2	1"1/2	59,0	67,0	50
100	TLBSPBSPTMA3232	2"	2"	78,0	76,0	65

ADATTATORE A «T» MASCHIO DI ESTREMITÀ LATERALE

Filetto Gas Cilindrico/NPT

MALE STUD BARREL TEE

Thread BSP Parallel/NPT

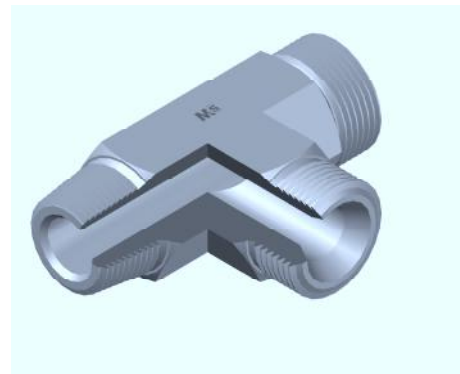
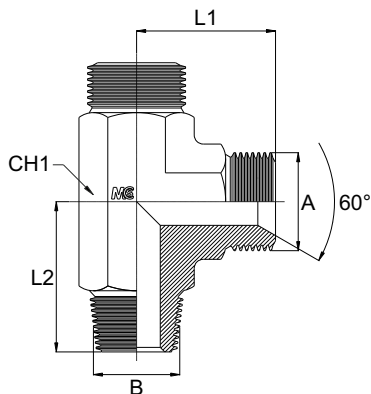

Bar W.P.	Codice Part Number	A	B	L1	L2	CH1
350	TLBSPNPTMA0202	1/8"	1/8"	21,0	20,0	12
	TLBSPNPTMA0404	1/4"	1/4"	26,0	28,0	14
250	TLBSPNPTMA0606	3/8"	3/8"	29,0	31,0	19
225	TLBSPNPTMA0808	1/2"	1/2"	34,0	37,5	22
200	TLBSPNPTMA1010	5/8"	5/8"	38,0	40,0	27
	TLBSPNPTMA1212	3/4"	3/4"	41,0	40,0	27
160	TLBSPNPTMA1616	1"	1"	45,0	50,0	33
	TLBSPNPTMA2020	1" 1/4	1" 1/4	52,0	60,0	41
	TLBSPNPTMA2424	1" 1/2	1" 1/2	59,0	67,0	50
100	TLBSPNPTMA3232	2"	2"	78,0	76,0	65

ADATTATORE A «T» MASCHIO DI ESTREMITÀ CENTRALE

Filetto Gas Cilindrico/Conico

MALE STUD BRANCH TEE

Thread BSP Parallel/BSP Taper

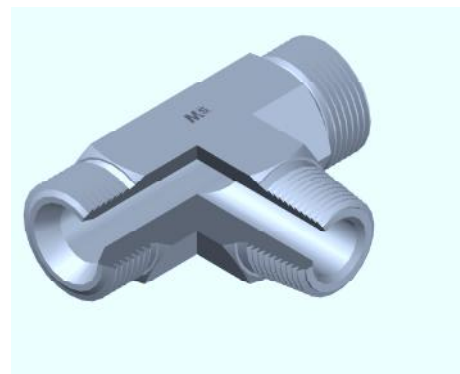
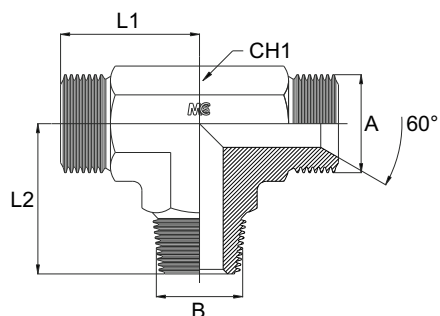

Bar W.P.	Codice Part Number	A	B	L1	L2	CH1
350	TCBSPBSPTMA0202	1/8"	1/8"	21,0	20,0	12
	TCBSPBSPTMA0404	1/4"	1/4"	26,0	28,0	14
250	TCBSPBSPTMA0606	3/8"	3/8"	29,0	31,0	19
225	TCBSPBSPTMA0808	1/2"	1/2"	34,0	37,5	22
200	TCBSPBSPTMA1010	5/8"	5/8"	38,0	40,0	27
	TCBSPBSPTMA1212	3/4"	3/4"	41,0	40,0	27
160	TCBSPBSPTMA1616	1"	1"	45,0	50,0	33
	TCBSPBSPTMA2020	1" 1/4	1" 1/4	52,0	60,0	41
	TCBSPBSPTMA2424	1" 1/2	1" 1/2	59,0	67,0	50
100	TCBSPBSPTMA3232	2"	2"	78,0	76,0	65

ADATTATORE A «T» MASCHIO DI ESTREMITÀ CENTRALE

Filetto Gas Cilindrico/NPT

MALE BRANCH TEE

Thread BSP Parallel/NPT

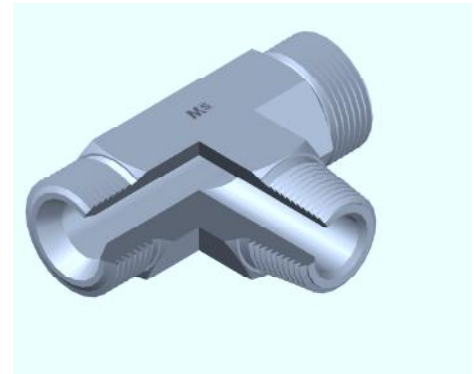
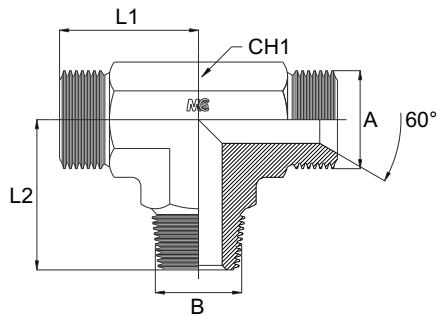

Bar W.P.	Codice Part Number	A	B	L1	L2	CH1
350	TCBSPNPTMA0202	1/8"	1/8"	21,0	20,0	12
	TCBSPNPTMA0404	1/4"	1/4"	26,0	28,0	14
250	TCBSPNPTMA0606	3/8"	3/8"	29,0	31,0	19
225	TCBSPNPTMA0808	1/2"	1/2"	34,0	37,5	22
200	TCBSPNPTMA1010	5/8"	5/8"	38,0	40,0	27
	TCBSPNPTMA1212	3/4"	3/4"	41,0	40,0	27
160	TCBSPNPTMA1616	1"	1"	45,0	50,0	33
	TCBSPNPTMA2020	1" 1/4	1" 1/4	52,0	60,0	41
	TCBSPNPTMA2424	1" 1/2	1" 1/2	59,0	67,0	50
100	TCBSPNPTMA3232	2"	2"	78,0	76,0	65

ADATTATORE A «T» INTERMEDIO FEMMINA

Filetto Gas Cilindrico

FEMALE EQUAL TEE

Thread BSP Parallel

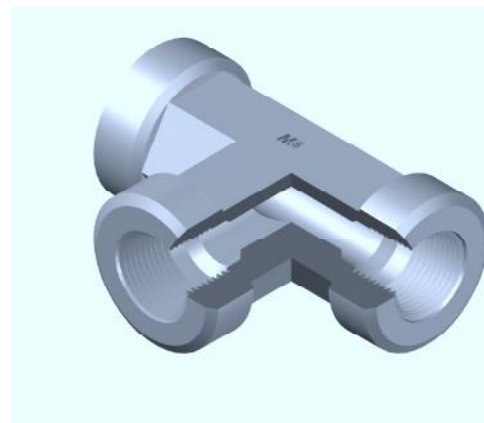
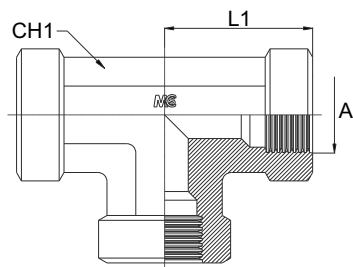

Bar W.P.	Codice Part Number	A	L1	CH1
350	TBSPFFA0202	1/8"	17,0	14
	TBSPFFA0404	1/4"	22,5	19
250	TBSPFFA0606	3/8"	26,0	22
225	TBSPFFA0808	1/2"	31,0	27
200	TBSPFFA1212	3/4"	34,5	33
160	TBSPFFA1616	1"	41,0	41
	TBSPFFA2020	1" 1/4	43,0	50
	TBSPFFA2424	1" 1/2	53,0	65
100	TBSPFFA3232	2"	61,0	70

ADATTATORE A «T» INTERMEDIO FEMMINA

Filetto NPT

FEMALE EQUAL TEE

Thread NPT

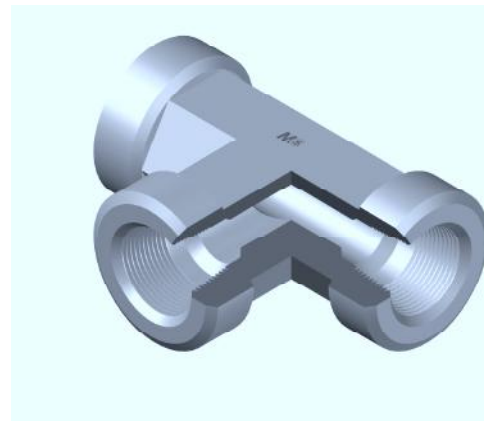
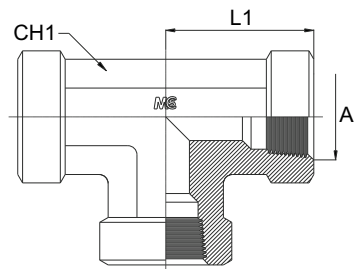

Bar W.P.	Codice Part Number	A	L1	CH1
350	TNPTFFA0202	1/8"	17,0	14
	TNPTFFA0404	1/4"	22,5	19
250	TNPTFFA0606	3/8"	26,0	22
225	TNPTFFA0808	1/2"	31,0	27
200	TNPTFFA1212	3/4"	34,5	33
160	TNPTFFA1616	1"	41,0	41
	TNPTFFA2020	1" 1/4	43,0	50
	TNPTFFA2424	1" 1/2	53,0	65
100	TNPTFFA3232	2"	61,0	70

ADATTATORE A «T» INTERMEDIO FEMMINA GIREVOLE

Filetto Gas Cilindrico

SWIVEL FEMALE EQUAL TEE

Thread BSP Parallel

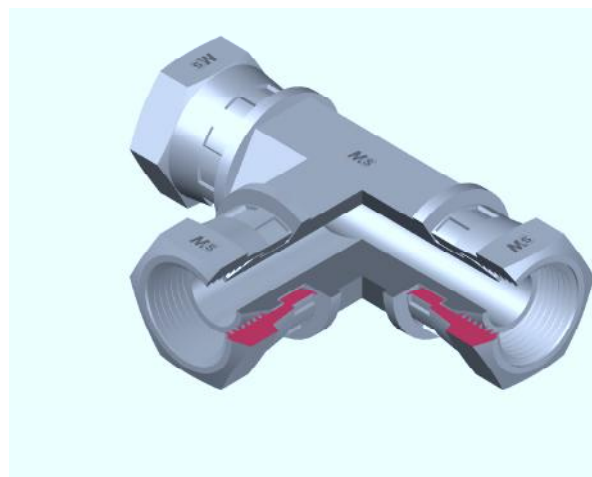
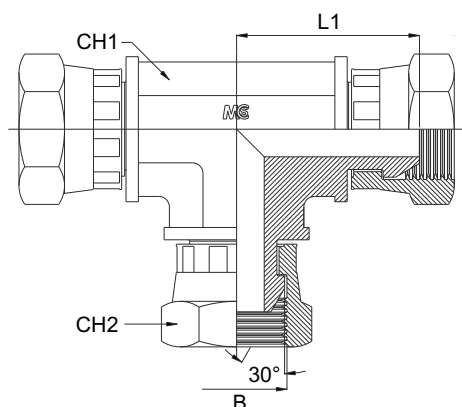

Bar W.P.	Codice Part Number	A	B	L1	CH1	CH2
400	TBSPSFA0202	1/8"	1/8"	18,0	12	17
	TBSPSFA0404	1/4"	1/4"	23,5	14	19
	TBSPSFA0606	3/8"	3/8"	25,5	19	22
350	TBSPSFA0808	1/2"	1/2"	29,5	22	27
	TBSPSFA1010	5/8"	5/8"	-	27	30
315	TBSPSFA1212	3/4"	3/4"	37,0	27	32
250	TBSPSFA1616	1"	1"	43,0	33	38
200	TBSPSFA2020	1"1/4	1"1/4	51,0	41	50
160	TBSPSFA2424	1"1/2	1"1/2	59,0	50	55
125	TBSPSFA3232	2"	2"	-	65	70

ADATTATORE A «T» INTERMEDIO FEMMINA GIREVOLE

Filetto Metrico Cilindrico

SWIVEL FEMALE EQUAL TEE

Thread Metric Parallel

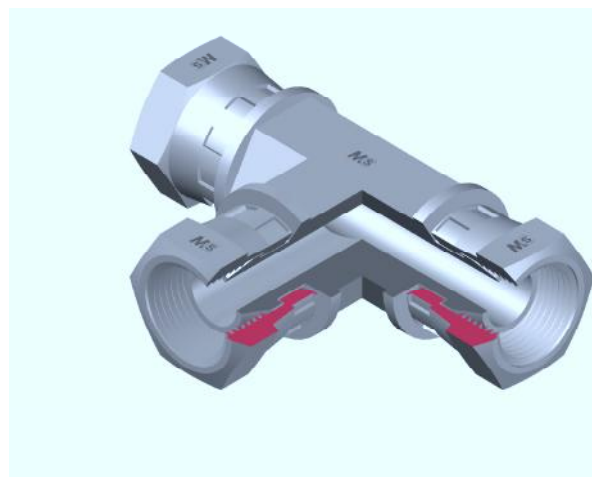
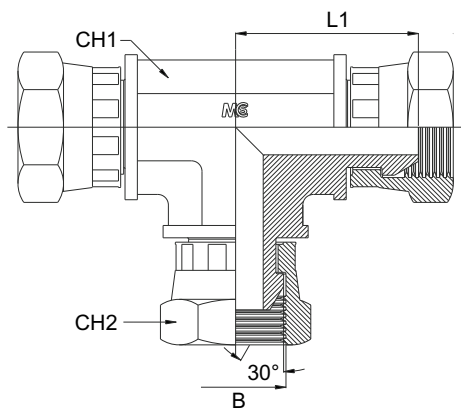

Bar W.P.	Codice Part Number	A	B	L1	CH1	CH2
400	TMSFA1212	12x1,5	12x1,5	18,0	12	17
	TMSFA1414	14x1,5	14x1,5	23,5	14	19
	TMSFA1616	16x1,5	16x1,5	25,5	19	22
	TMSFA1818	18x1,5	18x1,5	29,5	19	24
350	TMSFA2020	20x1,5	20x1,5	37,0	22	27
	TMSFA2222	22x1,5	22x1,5	43,0	22	27
315	TMSFA2626	26x1,5	26x1,5	51,0	27	32
250	TMSFA3030	30x1,5	30x1,5	59,0	33	36

ADATTATORE A «T» LATERALE MASCHIO/FEMMINA

Filetto Gas Conico/Cilindrico

MALE /FEMALE STUD BARREL TEE

Thread BSP Taper/BSP Parallel

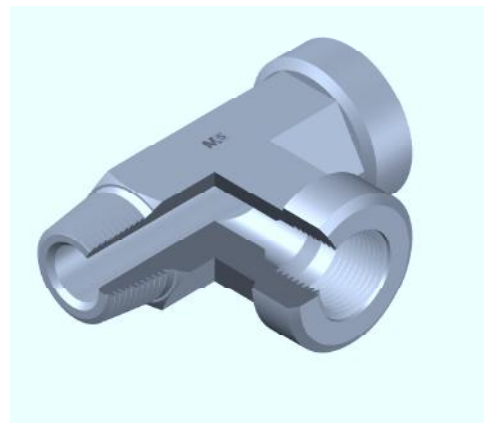
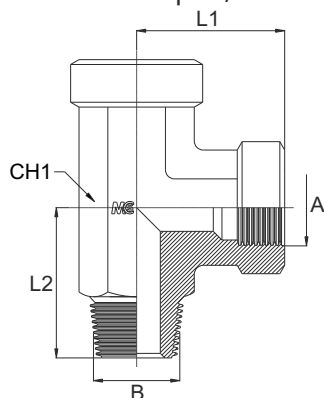

Bar W.P.	Codice Part Number	A	B	L1	L2	CH1
350	TLBSPTBSPMFA0202	1/8"	1/8"	17,0	20,0	14
	TLBSPTBSPMFA0404	1/4"	1/4"	22,5	28,0	19
250	TLBSPTBSPMFA0606	3/8"	3/8"	26,0	31,0	22
225	TLBSPTBSPMFA0808	1/2"	1/2"	31,0	37,5	27
200	TLBSPTBSPMFA1212	3/4"	3/4"	34,5	40,0	33
	TLBSPTBSPMFA1616	1"	1"	41,0	50,0	41
160	TLBSPTBSPMFA2020	1" 1/4	1" 1/4	43,0	60,0	50
	TLBSPTBSPMFA2424	1" 1/2	1" 1/2	53,0	67,0	65
100	TLBSPTBSPMFA3232	2"	2"	61,0	76,0	70

ADATTATORE A «T» LATERALE MASCHIO/FEMMINA

Filetto NPT/Gas Cilindrico

MALE/FEMALE STUD BARREL TEE

Thread NPT/BSP Parallel

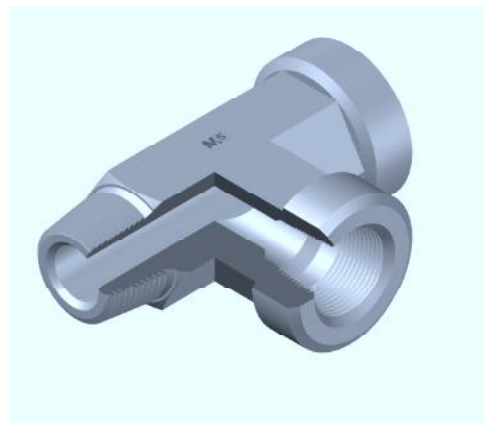
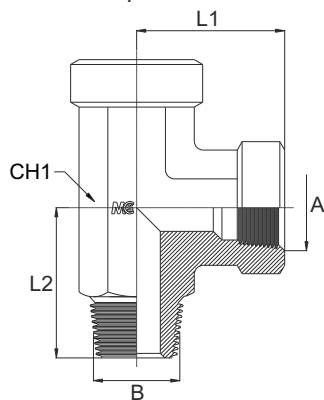

Bar W.P.	Codice Part Number	A	B	L1	L2	CH1
350	TLNPTBSPMFA0202	1/8"	1/8"	17,0	20,0	14
	TLNPTBSPMFA0404	1/4"	1/4"	22,5	28,0	19
250	TLNPTBSPMFA0606	3/8"	3/8"	26,0	31,0	22
225	TLNPTBSPMFA0808	1/2"	1/2"	31,0	37,5	27
200	TLNPTBSPMFA1212	3/4"	3/4"	34,5	40,0	33
	TLNPTBSPMFA1616	1"	1"	41,0	50,0	41
160	TLNPTBSPMFA2020	1"1/4	1"1/4	43,0	60,0	50
	TLNPTBSPMFA2424	1"1/2	1"1/2	53,0	67,0	65
100	TLNPTBSPMFA3232	2"	2"	61,0	76,0	70

ADATTATORE A «T» CENTRALE MASCHIO/FEMMINA

Filetto Gas Conico/Cilindrico

MALE/FEMALE STUD BRANCH TEE

Thread BSP Taper/BSP Parallel

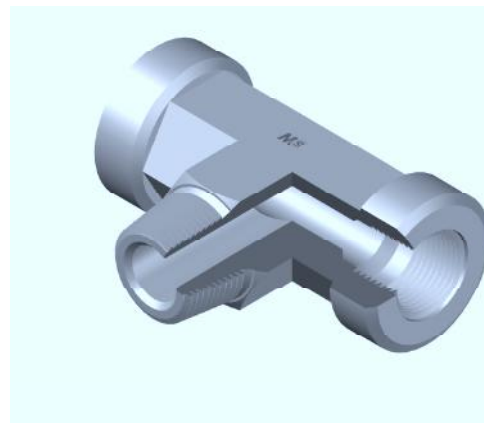
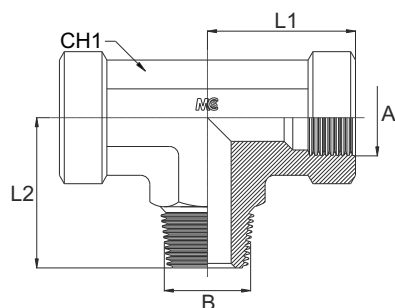

Bar W.P.	Codice Part Number	A	B	L1	L2	CH1
350	TCBSPTBSPMFA0202	1/8"	1/8"	17,0	20,0	14
	TCBSPTBSPMFA0404	1/4"	1/4"	22,5	28,0	19
250	TCBSPTBSPMFA0606	3/8"	3/8"	26,0	31,0	22
225	TCBSPTBSPMFA0808	1/2"	1/2"	31,0	37,5	27
200	TCBSPTBSPMFA1212	3/4"	3/4"	34,5	40,0	33
	TCBSPTBSPMFA1616	1"	1"	41,0	50,0	41
160	TCBSPTBSPMFA2020	1" 1/4	1" 1/4	43,0	60,0	50
	TCBSPTBSPMFA2424	1" 1/2	1" 1/2	53,0	67,0	65
100	TCBSPTBSPMFA3232	2"	2"	61,0	76,0	70

ADATTATORE A «T» CENTRALE MASCHIO/FEMMINA

Filetto NPT/Gas Cilindrico

MALE/FEMALE STUD BRANCH TEE

Thread NPT/BSP Parallel

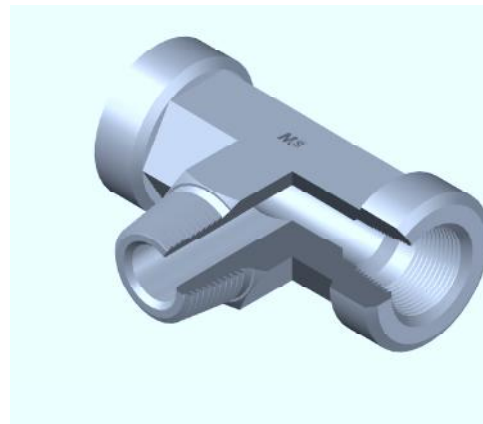
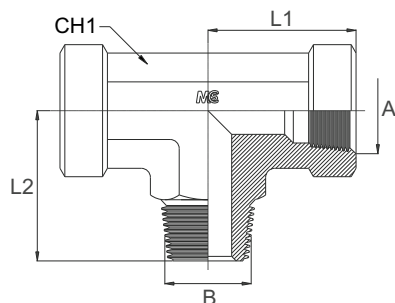

Bar W.P.	Codice Part Number	A	B	L1	L2	CH1
350	TCNPTBSPMFA0202	1/8"	1/8"	17,0	20,0	14
	TCNPTBSPMFA0404	1/4"	1/4"	22,5	28,0	19
250	TCNPTBSPMFA0606	3/8"	3/8"	26,0	31,0	22
225	TCNPTBSPMFA0808	1/2"	1/2"	31,0	37,5	27
200	TCNPTBSPMFA1212	3/4"	3/4"	34,5	40,0	33
	TCNPTBSPMFA1616	1"	1"	41,0	50,0	41
160	TCNPTBSPMFA2020	1"1/4	1"1/4	43,0	60,0	50
	TCNPTBSPMFA2424	1"1/2	1"1/2	53,0	67,0	65
100	TCNPTBSPMFA3232	2"	2"	61,0	76,0	70

ADATTATORE A «T» LATERALE MASCHIO/FEMMINA GIREVOLE

Filetto Gas Cilindrico

MALE/SWIVEL FEMALE STUD BARREL TEE

Thread BSP Parallel

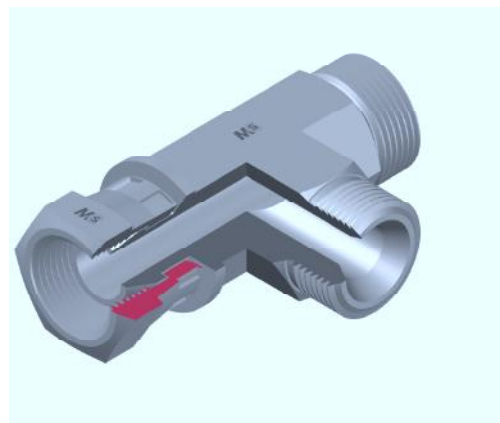
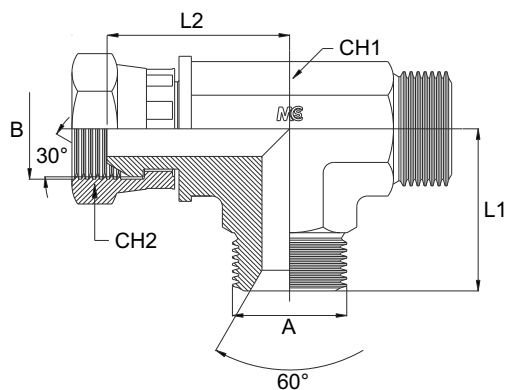

Bar W.P.	Codice Part Number	A	B	L1	L2	CH1	CH2
400	TLBSPMSFA0202	1/8"	1/8"	21,0	18,0	12	17
	TLBSPMSFA0404	1/4"	1/4"	26,0	23,5	14	19
	TLBSPMSFA0606	3/8"	3/8"	29,0	25,5	19	22
350	TLBSPMSFA0808	1/2"	1/2"	34,0	29,5	22	27
	TLBSPMSFA1010	5/8"	5/8"	38,0	-	27	30
315	TLBSPMSFA1212	3/4"	3/4"	41,0	37,0	27	32
250	TLBSPMSFA1616	1"	1"	45,0	43,0	33	38
200	TLBSPMSFA2020	1" 1/4	1" 1/4	57,0	51,0	41	50
160	TLBSPMSFA2424	1" 1/2	1" 1/2	59,0	59,0	50	55
125	TLBSPMSFA3232	2"	2"	78,0	-	65	70

ADATTATORE A «T» LATERALE MASCHIO/FEMMINA GIREVOLE

Filetto Metrico Cilindrico

MALE/SWIVEL FEMALE STUD BARREL TEE

Thread Metric Parallel

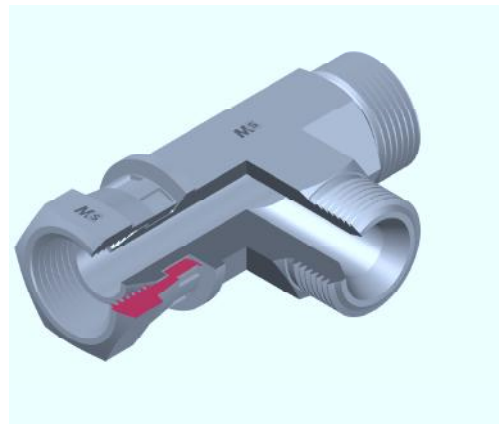
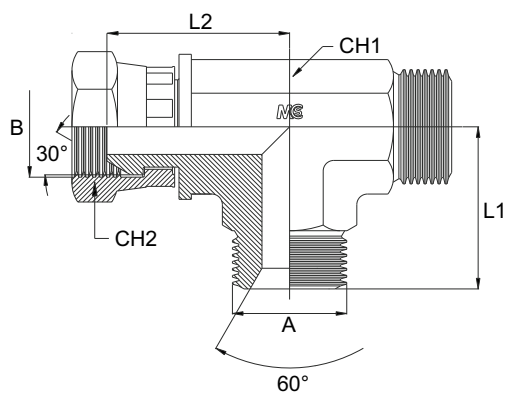

Bar W.P.	Codice Part Number	A	B	L1	L2	CH1	CH2
400	TLMMSFA1212	12x1,5	12x1,5	21,0	18,0	12	17
	TLMMSFA1414	14x1,5	14x1,5	26,0	23,5	14	19
	TLMMSFA1616	16x1,5	16x1,5	29,0	25,5	19	22
	TLMMSFA1818	18x1,5	18x1,5	29,0	29,5	19	24
350	TLMMSFA2020	20x1,5	20x1,5	34,0	37,0	22	27
	TLMMSFA2222	22x1,5	22x1,5	34,0	43,0	22	27
315	TLMMSFA2626	26x1,5	26x1,5	41,0	51,0	27	32
250	TLMMSFA3030	30x1,5	30x1,5	45,0	59,0	33	36

ADATTATORE A «T» CENTRALE MASCHIO/FEMMINA GIREVOLE

Filetto Gas Cilindrico

MALE/SWIVEL FEMALE STUD BRANCH TEE

Thread BSP Parallel

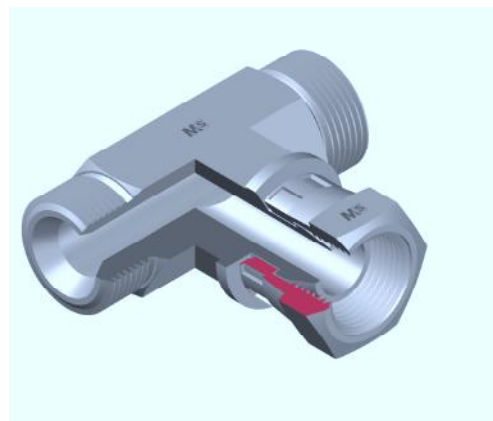
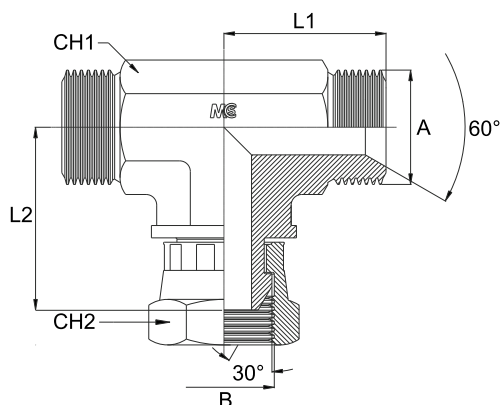

Bar W.P.	Codice Part Number	A	B	L1	L2	CH1	CH2
400	TCBSPMSFA0202	1/8"	1/8"	21,0	18,0	12	17
	TCBSPMSFA0404	1/4"	1/4"	26,0	23,5	14	19
	TCBSPMSFA0606	3/8"	3/8"	29,0	25,5	19	22
350	TCBSPMSFA0808	1/2"	1/2"	34,0	29,5	22	27
	TCBSPMSFA1010	5/8"	5/8"	38,0	-	27	30
315	TCBSPMSFA1212	3/4"	3/4"	41,0	37,0	27	32
250	TCBSPMSFA1616	1"	1"	45,0	43,0	33	38
200	TCBSPMSFA2020	1" 1/4	1" 1/4	57,0	51,0	41	50
160	TCBSPMSFA2424	1" 1/2	1" 1/2	59,0	59,0	50	55
125	TCBSPMSFA3232	2"	2"	78,0	-	65	70

ADATTATORE A «T» CENTRALE MASCHIO/FEMMINA GIREVOLE

Filetto Metrico Cilindrico

MALE/SWIVEL FEMALE STUD BRANCH TEE

Thread Metric Parallel

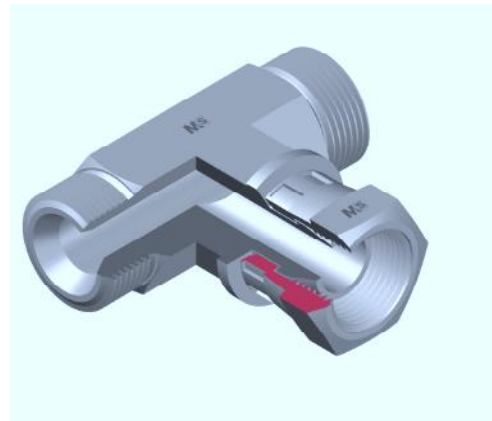
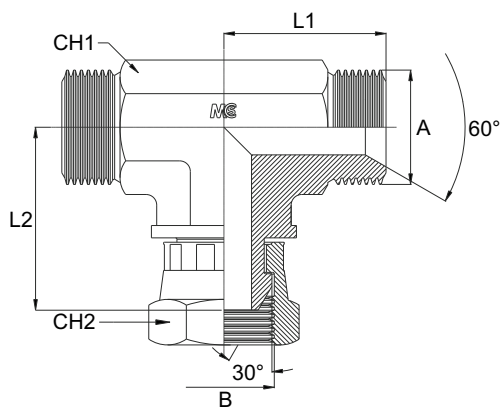

Bar W.P.	Codice Part Number	A	B	L1	L2	CH1	CH2
400	TCMMSFA1212	12x1,5	12x1,5	21,0	18,0	12	17
	TCMMSFA1414	14x1,5	14x1,5	26,0	23,5	14	19
	TCMMSFA1616	16x1,5	16x1,5	29,0	25,5	19	22
	TCMMSFA1818	18x1,5	18x1,5	29,0	29,5	19	24
350	TCMMSFA2020	20x1,5	20x1,5	34,0	37,0	22	27
	TCMMSFA2222	22x1,5	22x1,5	34,0	43,0	22	27
315	TCMMSFA2626	26x1,5	26x1,5	41,0	51,0	27	32
250	TCMMSFA3030	30x1,5	30x1,5	45,0	59,0	33	36

ADATTATORE A CROCE INTERMEDIO MASCHIO

Filetto Gas Cilindrico

MALE EQUAL CROSS

Thread BSP Parallel

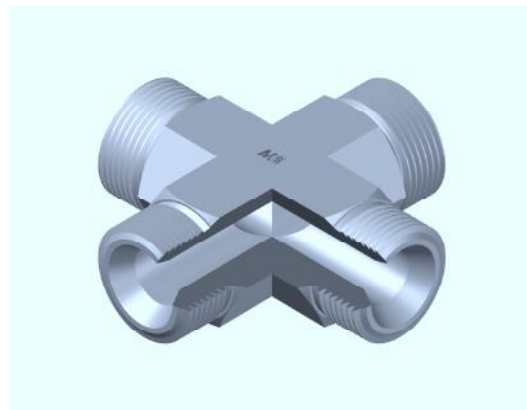
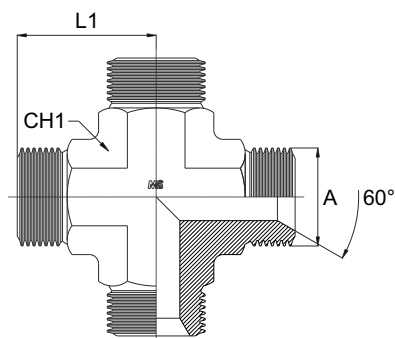

Bar W.P.	Codice Part Number	A	L1	CH1
400	CRBSPMA02	1/8"	21,0	12
	CRBSPMA04	1/4"	26,0	14
	CRBSPMA06	3/8"	29,0	19
350	CRBSPMA08	1/2"	34,0	22
	CRBSPMA10	5/8"	38,0	27
315	CRBSPMA12	3/4"	41,0	27
250	CRBSPMA16	1"	45,0	33
200	CRBSPMA20	1" 1/4	52,0	41
160	CRBSPMA24	1" 1/2	59,0	50
125	CRBSPMA32	2"	78,0	65

ADATTATORE A CROCE INTERMEDIO FEMMINA

Filetto Gas Cilindrico

FEMALE EQUAL CROSS

Thread BSP Parallel

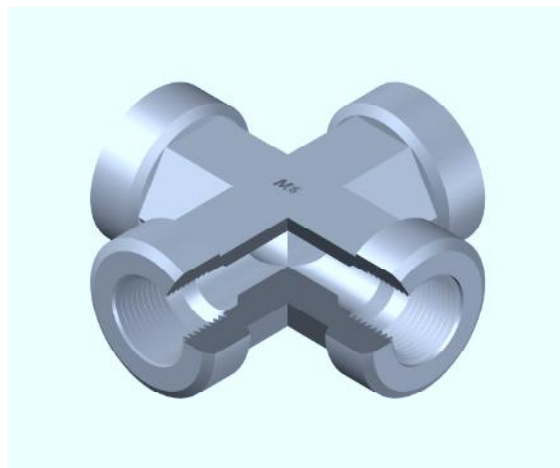
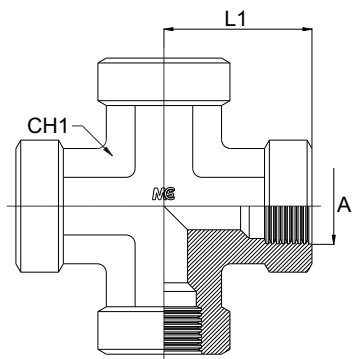

Bar W.P.	Codice Part Number	A	L1	CH1
350	CRBSPFFA02	1/8"	17,0	14
	CRBSPFFA04	1/4"	22,5	19
250	CRBSPFFA06	3/8"	26,0	22
225	CRBSPFFA08	1/2"	31,0	27
200	CRBSPFFA12	3/4"	34,5	33
	CRBSPFFA16	1"	41,0	41
160	CRBSPFFA20	1"1/4	43,0	50
	CRBSPFFA24	1"1/2	53,0	65
100	CRBSPFFA32	2"	61,0	70

TAPPO MASCHIO

Filetto Gas Cilindrico

MALE PLUG

Thread BSP Parallel

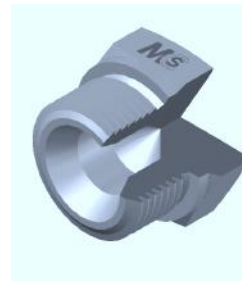
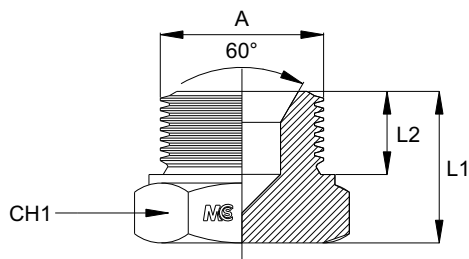

Bar W.P.	Codice Part Number	A	L1	L2	CH1
400	BSPMHP02	1/8"	16,5	8,0	14
	BSPMHP04	1/4"	19,5	11,0	19
	BSPMHP06	3/8"	21,0	12,0	22
350	BSPMHP08	1/2"	24,0	14,0	27
	BSPMHP10	5/8"	27,0	16,0	30
315	BSPMHP12	3/4"	27,0	16,0	32
250	BSPMHP16	1"	32,0	19,0	41
200	BSPMHP20	1" 1/4	34,0	20,0	50
160	BSPMHP24	1" 1/2	37,0	20,0	55
125	BSPMHP32	2"	41,0	24,5	70

TAPPO MASCHIO

Filetto Metrico Cilindrico

MALE PLUG

Thread Metric Parallel

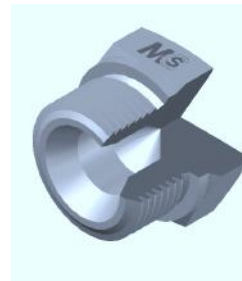
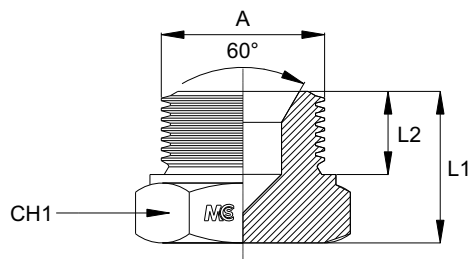

Bar W.P.	Codice Part Number	A	L1	L2	CH1
400	MMHP12	12x1,5	18,0	11,0	17
	MMHP14	14x1,5	18,0	11,0	19
	MMHP16	16x1,5	20,5	12,0	22
	MMHP18	18x1,5	22,0	14,0	24
350	MMHP20	20x1,5	24,0	14,0	27
	MMHP22	22x1,5	24,0	14,0	27
315	MMHP24	24x1,5	25,0	16,0	30
	MMHP26	26x1,5	26,0	16,0	32
250	MMHP28	28x1,5	26,0	16,0	34
	MMHP30	30x1,5	29,0	16,0	38

TAPPO MASCHIO

Filetto Gas Conico

MALE PLUG

Thread BSP Taper

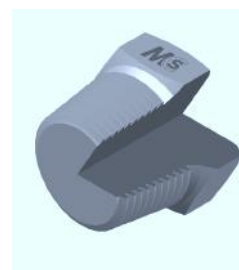
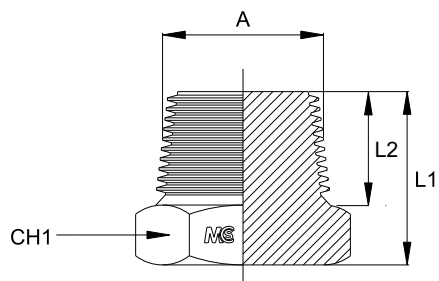

Bar W.P.	Codice Part Number	A	L1	L2	CH1
350	BSPTMHP02	1/8"	16,0	8,0	14
300	BSPTMHP04	1/4"	20,5	12,5	14
280	BSPTMHP06	3/8"	22,0	13,9	19
200	BSPTMHP08	1/2"	25,0	17,0	22
	BSPTMHP12	3/4"	26,5	17,5	27
120	BSPTMHP16	1"	32,0	22,0	36
105	BSPTMHP20	1"1/4	35,0	24,0	46
	BSPTMHP24	1"1/2	35,5	24,0	50
70	BSPTMHP32	2"	39,0	25,0	65

TAPPO MASCHIO

Filetto NPT

MALE PLUG

Thread NPT

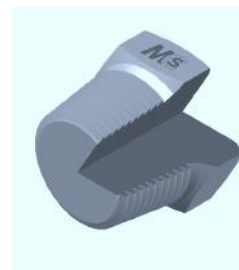
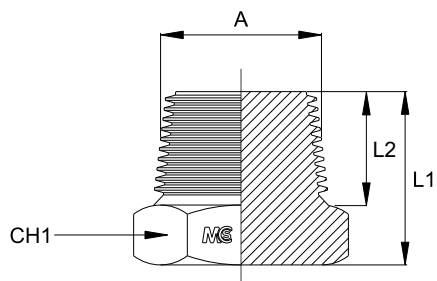

Bar W.P.	Codice Part Number	A	L1	L2	CH1
350	NPTMHP02	1/8"	17,0	10,0	14
	NPTMHP04	1/4"	21,0	14,0	14
250	NPTMHP06	3/8"	22,0	14,0	19
225	NPTMHP08	1/2"	27,0	19,0	22
200	NPTMHP12	3/4"	29,0	19,0	27
	NPTMHP16	1"	34,0	24,0	36
160	NPTMHP20	1" 1/4	36,0	25,0	46
	NPTMHP24	1" 1/2	36,0	25,0	50
100	NPTMHP32	2"	40,0	26,0	65

TAPPO FEMMINA FISSA

Filetto Gas Cilindrico

FIXED FEMALE PLUG

Thread BSP Parallel

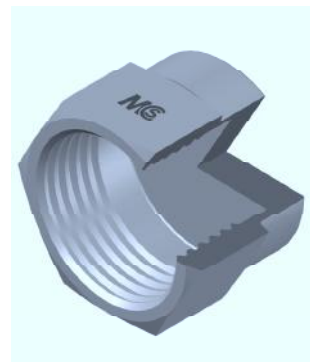
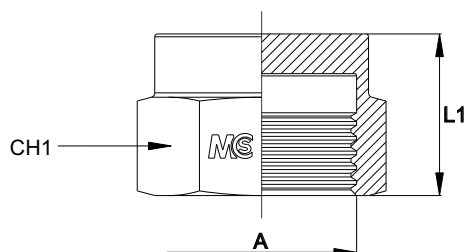

Bar W.P.	Codice Part Number	A	L1	CH1
400	BSPFHP04	1/4"	17,5	19
	BSPFHP06	3/8"	20,0	22
350	BSPFHP08	1/2"	23,0	27
	BSPFHP10	5/8"	24,0	30
315	BSPFHP12	3/4"	26,5	32
250	BSPFHP16	1"	28,5	38
200	BSPFHP20	1" 1/4	33,0	50
160	BSPFHP24	1" 1/2	33,0	55
125	BSPFHP32	2"	42,0	70

TAPPO FEMMINA FISSA

Filetto Metrico Cilindrico

FIXED FEMALE PLUG

Thread Metric Parallel

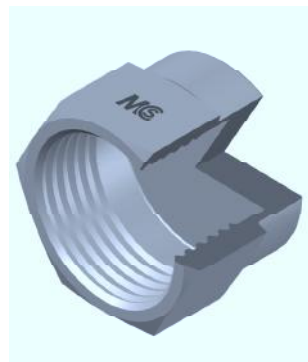
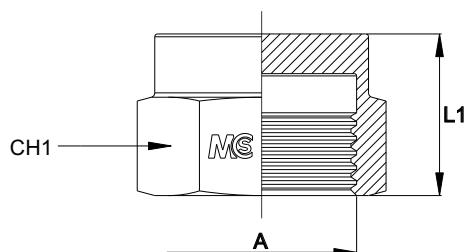

Bar W.P.	Codice Part Number	A	L1	CH1
400	MFHP12	12x1,5	17,0	17
	MFHP14	14x1,5	17,0	19
	MFHP16	16x1,5	21,0	22
	MFHP18	18x1,5	22,0	24
350	MFHP20	20x1,5	22,0	27
	MFHP22	22x1,5	22,0	27
315	MFHP24	24x1,5	24,0	30
	MFHP26	26x1,5	26,0	32
250	MFHP28	28x1,5	26,0	36

TAPPO FEMMINA GIREVOLE

Filetto Gas Cilindrico

SWIVEL FEMALE PLUG

Thread BSP Parallel

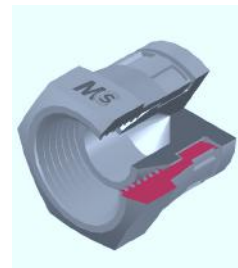
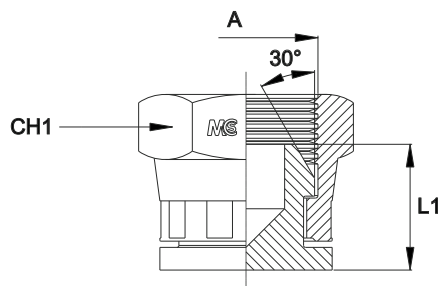

Bar W.P.	Codice Part Number	A	L1	CH1
400	BSPSFHP04	1/4"	13,5	19
	BSPSFHP06	3/8"	15,5	22
350	BSPSFHP08	1/2"	17,5	27
	BSPSFHP10	5/8"	17,5	30
315	BSPSFHP12	3/4"	20,0	32
250	BSPSFHP16	1"	21,8	38
200	BSPSFHP20	1" 1/4	21,0	50
160	BSPSFHP24	1" 1/2	25,5	55